



BELLE  
LIGHT  
CONSTRUCTION  
EQUIPMENT



Altrad-Belle.com

# PCLX 32E+, 32SE+ & 40E+

GB Operators Manual

4

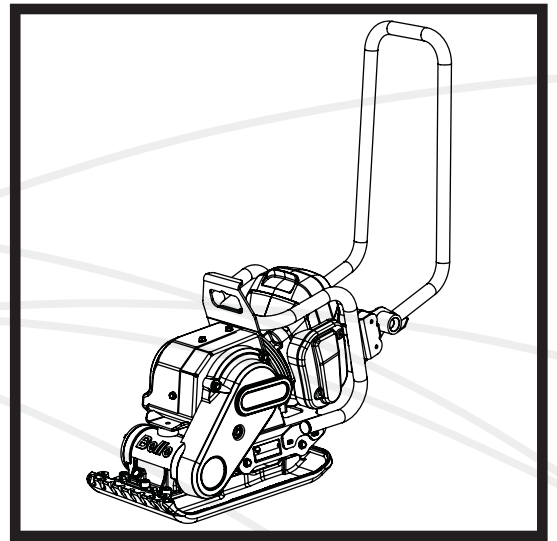

2

UKCA Declaration of Conformity

3

EC/EU Declaration of Conformity

# Declaration Of Conformity (DOC)

We, **Altrad Belle, Sheen, Nr. Buxton, Derbyshire, SK17 0EU, GB** declare that the DoC is issued under our sole responsibility and belongs to the followings product(s):



PRODUCT TYPE .....

MODEL.....

SERIAL No.....

DATE OF MANUFACTURE

SOUND POWER LEVEL  
MEASURED /  
.....(GUARANTEED)

WEIGHT.....



## Object of the Declaration:

Battery powered single-direction plate compactor used for soil compaction on new developments, repairs and maintenance jobs with large aggregates, cohesive material or moist content.

The object of the declaration described above is in conformity with the relevant **Statutory Requirements**:

- **2008 No. 1597** Supply of Machinery (Safety) Regulations 2008
- **2001 No. 1701** Noise Emission in the Environment by Equipment for use Outdoors Regulations 2001
- **2016 No. 1091** Electromagnetic Compatibility Regulations 2016
- **2012 No. 3032** The Restriction of the Use of Certain Hazardous Substances in Electrical and Electronic Equipment Regulations 2012

The following designated standards and technical specifications have been applied:

- **EN ISO 12100:2010** Safety of machinery
- **EN 500-4:2011** Mobile road construction machinery. Safety.
- **ISO 3744:2010** Acoustics — Determination of sound power levels and sound energy levels of noise sources using sound pressure

**ANP CERTIFICATION LTD. (Approved Body, number 8500) 2 Parkfield Street, Manchester, M14 4PN, UK** carried out Internal Control of Production with Assessment of Technical Documentation and Periodical Checking as per Schedule 9 of SI 2001 1701

Technical Files are held by **Mark Pickard** at the Altrad Belle address stated above:-

## Place of Declaration:-

Sheen,  
Nr. Buxton,  
Derbyshire,  
SK17 0EU,  
UK

Signed by:

Mark Pickard

## Date of Declaration:-

April 2026

**Managing Director**  
On behalf of Altrad Belle  
Sheen, Derbyshire, UK



# EC Declaration Of Conformity (DOC)



We, **Altrad Belle, Sheen, Nr. Buxton, Derbyshire, SK17 0EU, GB** declare that the DoC is issued under our sole responsibility and belongs to the followings product(s):



PRODUCT TYPE .....

MODEL.....

SERIAL No.....

DATE OF MANUFACTURE .....

SOUND POWER LEVEL  
MEASURED /  
.....(GUARANTEED)

WEIGHT.....



Signed by:

**Mark Pickard**  
**Managing Director**

*On behalf of Altrad Belle, Sheen, Derbyshire, UK*

**Place of Declaration:-**  
*Sheen, Nr. Buxton, Derbyshire, SK17 0EU, UK*

**Date of Declaration:-**  
*April 2026*

**Object of the Declaration:**

Battery powered single-direction plate compactor used for soil compaction on new developments, repairs and maintenance jobs with large aggregates, cohesive material or moist content.

The object of the declaration described above is in conformity with the relevant **Union Harmonisation Legislation:**

- **2006/42/EC** - New machinery directive
- **2000/14/EC** - Noise - equipment for use outdoors

The following harmonised standards and technical specifications have been applied:

- **EN ISO 12100:2010** Safety of machinery
- **EN 500-4:2011** Mobile road construction machinery. Safety.
- **ISO 3744:2010** Acoustics — Determination of sound power levels and sound energy levels of noise sources using sound pressure

**VINÇOTTE nv/sa (NB0026)** located Jan Olieslagerslaan 35, 1800 Vilvoorde, Belgium, carried out Internal Control of Production with Assessment of Technical Documentation and Periodical Checking as per Annex VI of 2000/14/EC

Technical Files are held by **Armand Ternel** at the following address:-  
**Altrad Investment Authority SAS:** 150 Rue Le Pérugin, 34000 Montpellier, France.



# EU Declaration Of Conformity (DOC)



We, **Altrad Belle, Sheen, Nr. Buxton, Derbyshire, SK17 0EU, GB** declare that the DoC is issued under our sole responsibility and belongs to the followings product(s):



PRODUCT TYPE .....

MODEL.....

SERIAL No.....

DATE OF MANUFACTURE .....

SOUND POWER LEVEL  
MEASURED /  
.....(GUARANTEED)

WEIGHT.....



Signed by:

**Mark Pickard**  
**Managing Director**

*On behalf of Altrad Belle, Sheen, Derbyshire, UK*

**Place of Declaration:-**  
*Sheen, Nr. Buxton, Derbyshire, SK17 0EU, UK*

**Date of Declaration:-**  
*April 2026*

**Object of the Declaration:**

Battery powered single-direction plate compactor used for soil compaction on new developments, repairs and maintenance jobs with large aggregates, cohesive material or moist content.

The object of the declaration described above is in conformity with the relevant **Union Harmonisation Legislation:**

- **2014/30/EU** - EMC Directive
- **2011/65/EU** - Restriction of Hazardous Substances Directive

The following harmonised standards and technical specifications have been applied:

- **EN ISO 12100:2010** Safety of machinery
- **EN 500-4:2011** Mobile road construction machinery. Safety.
- **ISO 3744:2010** Acoustics — Determination of sound power levels and sound energy levels of noise sources using sound pressure

**VINÇOTTE nv/sa (NB0026)** located Jan Olieslagerslaan 35, 1800 Vilvoorde, Belgium, carried out Internal Control of Production with Assessment of Technical Documentation and Periodical Checking as per Annex VI of 2000/14/EC

Technical Files are held by **Armand Ternel** at the following address:-  
**Altrad Investment Authority SAS:** 150 Rue Le Pérugin, 34000 Montpellier, France.



# Contents

<b><u>CONTENTS</u></b>	<b><u>PAGE NUMBER</u></b>
<b>UKCA DECLARATION OF CONFORMITY .....</b>	<b>2</b>
<b>CE/EU DECLARATION OF CONFORMITY .....</b>	<b>3</b>
<b>INTRODUCTION .....</b>	<b>5</b>
WARNING .....	5
Serial Numbers.....	6
<b>MACHINE DESCRIPTION</b>	
General.....	6
Standard Operation .....	6
Danger Zone .....	6
Main Components Locations.....	7
Power Unit Components .....	8
Battery Pack Components.....	8
Battery Charger .....	9
<b>TECHNICAL DATA</b>	
Static Dimensions.....	10
General Data .....	11
Batteries .....	11
Battery Charger .....	11
<b>SAFETY INSTRUCTIONS</b>	
General.....	12
Pre-Start Checks .....	12
Worksites.....	12
Operating the Machine .....	12 - 13
Battery Park.....	13
Battery Charger .....	14
Weather Conditions.....	15
During Maintenance .....	15
After Maintenance .....	15
Modifications & Replacement Parts .....	15
Safety Decals .....	16 - 17
<b>OPERATING INSTRUCTIONS</b>	
Reasons for Compaction.....	18
Applications .....	18
Compaction Specification.....	18 - 19
Charging the Battery Pack .....	19
Inserting the Battery Pack .....	19
Stopping the Power Unit.....	19
Starting the Power Unit .....	19
Removing the Battery Pack.....	20
Check the Charge Level of the Battery Pack .....	20
Battery Charging .....	20
Transportation .....	21
Operating the Machine .....	21
<b>STORAGE.....</b>	<b>22</b>
<b>ENVIRONMENT.....</b>	<b>22</b>
<b>SERVICE AND MAINTENANCE</b>	
General.....	23
Cleaning .....	23
<b>TROUBLESHOOTING GUIDE</b>	
Power Unit & Operation.....	24
Battery Pack & Charger.....	24
<b>'DUAL FORCE' / HAUC / NRSWA CERTIFICATE .....</b>	<b>25</b>
<b>WARRANTY.....</b>	<b>25</b>
<b>REPLACEMENT PARTS .....</b>	<b>25</b>

The purpose of this publication is to enable the owner/operator to maintain and use the machine efficiently. If these instructions are followed carefully they will contribute to years of efficient and profitable operation of the machines in the true Altrad Belle tradition.

The variations in operating conditions make it impossible for the company to make comprehensive or definite statements in its publications regarding performance and methods of use of its machines, or to accept any liability for any loss or damage which may result from these statements, or from any errors or omissions.

When replacements are required, insist on genuine Altrad Belle parts, as extensive damage is liable to result from the use of inferior quality parts.

In accordance with the company's policy of continuous improvement to its machines, alteration to the specifications of machines may be made at any time without notice and the company accepts no responsibility for any discrepancies which may occur between the specifications of its machines and the descriptions thereof contained in this publications.

This manual has been written to include all factory fitted options and specifications for world-wide use, but this does not imply that all or any of these are included in the standard machine configuration. Therefore local Altrad Belle Dealer's must always be consulted about machine specifications.

This manual may not in part, or in whole, be copied, photocopied, reproduced, translated, or converted to any electronic or machine readable form without written consent of Altrad Belle.

### Directives with regard to the notations.

Text in this manual to which special attention must be paid are shown in the following way:



#### **CAUTION**

*The product can be at risk. The machine or yourself can be damaged or injured if procedures are not carried out in the correct way.*



#### **WARNING**

*The life of the operator can be at risk.*

# WARNING



#### **WARNING**

*Before you operate or carry out any maintenance on this machine **YOU MUST READ** and **STUDY** this manual.*

**KNOW** how to safely use the unit's controls and what you must do for safe maintenance. (NB Be sure that you know how to switch the machine off before you switch on, in case you get into difficulty.)

**ALWAYS** wear or use the proper safety items required for your personal protection. If you have **ANY QUESTIONS** about the safe use or maintenance of this unit, ASK YOUR SUPERVISOR OR CONTACT: **Altrad Belle (UK): +44 (0) 1298 84606**



## Serial Numbers

**ENSURE** you make a note of the serial numbers of your machine and always quote them in any communication with Altrad Belle or one of our dealers.

### **A - MACHINE SERIAL NUMBER**

### **B - POWER UNIT SERIAL NUMBER**



## Machine Description

### **GENERAL**

Professional compaction plate designed with an emission free, Li-ion battery powered motor for all your compaction requirements, indoor usage and poorly ventilated areas.

Produces low HAV values and matches the high performance compaction of its petrol powered equivalent, but without the environmental impact... ***Building a Sustainable Future!***

### **STANDARD OPERATION**

The machine is intended to be used for the following, in safe environmental conditions as described in this manual.

- Cohesive materials (less than 20% granular) e.g clay, silt & heavy soils.
- Granular materials (more than 20% granular) e.g hard core, sand & light soils.
- Bituminous materials e.g asphalt (tarmac), cold lay (bitumin emulsion products).

Any other use is not deemed suitable for this machine. Altrad Belle will not liable for any damage or injury resulting from any use other than outlined above. The operator will be liable.

Any unauthorised modifications or attachments are prohibited. They may affect the performance and safety of the machine, potentially resulting in damage to the machine or injury to the operator.

Use of non-genuine replacement parts may also affect the performance and safety of the machine. potentially resulting in damage to the machine or injury to the operator.

### **DANGER ZONE**

The danger zone is the area around the machine in which persons are endangered during standard operation as outlined above.

During operation of the machine, cordon off the work area and keep members of the public and unauthorized personnel at a safe distance away from the danger zone.

## MAIN COMPONENT LOCATIONS

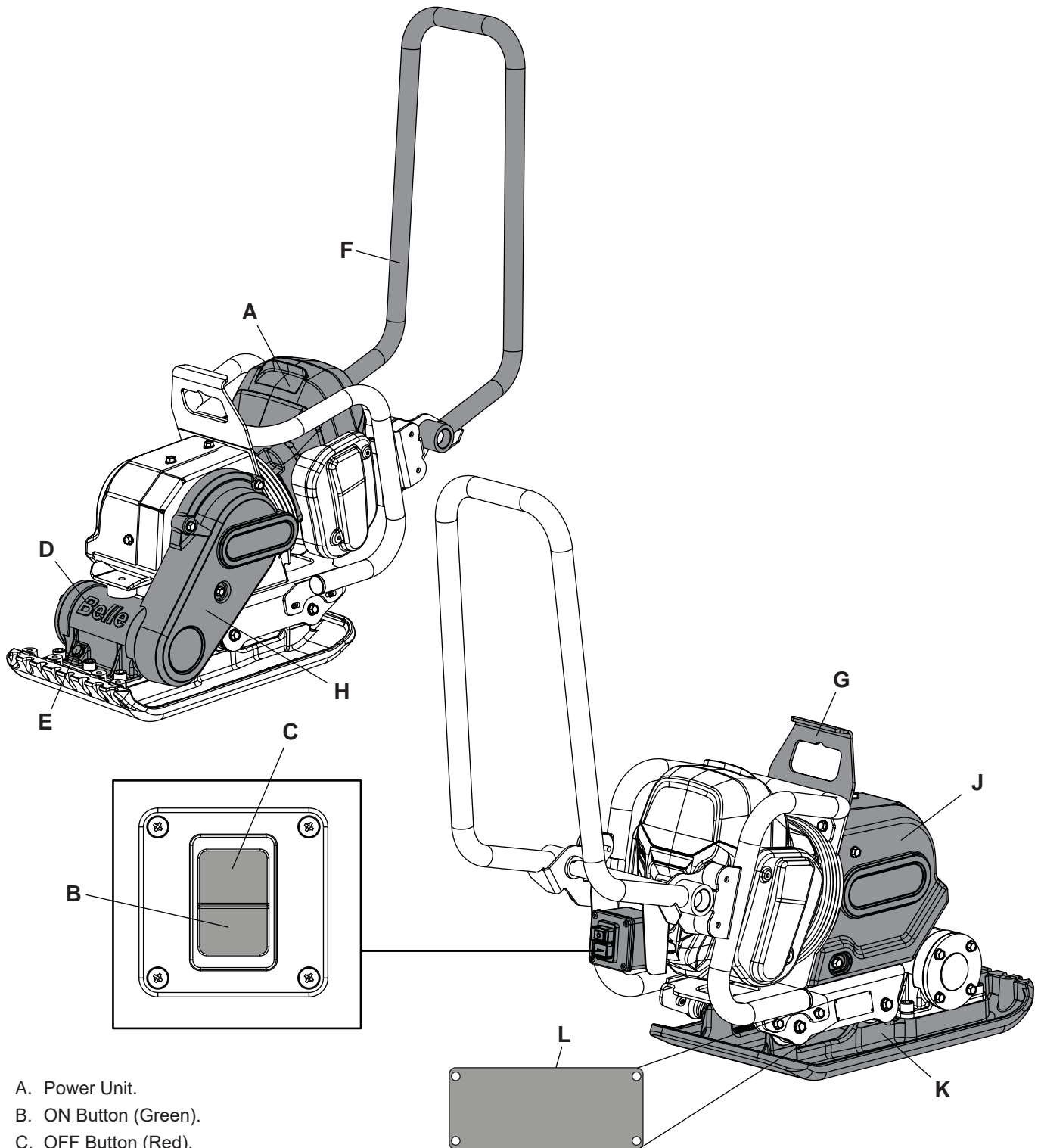

- A. Power Unit.
- B. ON Button (Green).
- C. OFF Button (Red).
- D. Vibrator / Vibrator Housing.
- E. Vibrator Oil Check Plug.
- F. Control Handle.
- G. Lifting Eye.
- H. Belt Guard
- J. Motor Housing
- K. Baseplate
- L. Serial Plate

## POWER UNIT COMPONENTS

- A. Battery Pack Compartment.
- B. Battery Pack Compartment Lid.
- C. Battery Retaining Latch.
- D. Serial Label
- E. Air Vent Intake

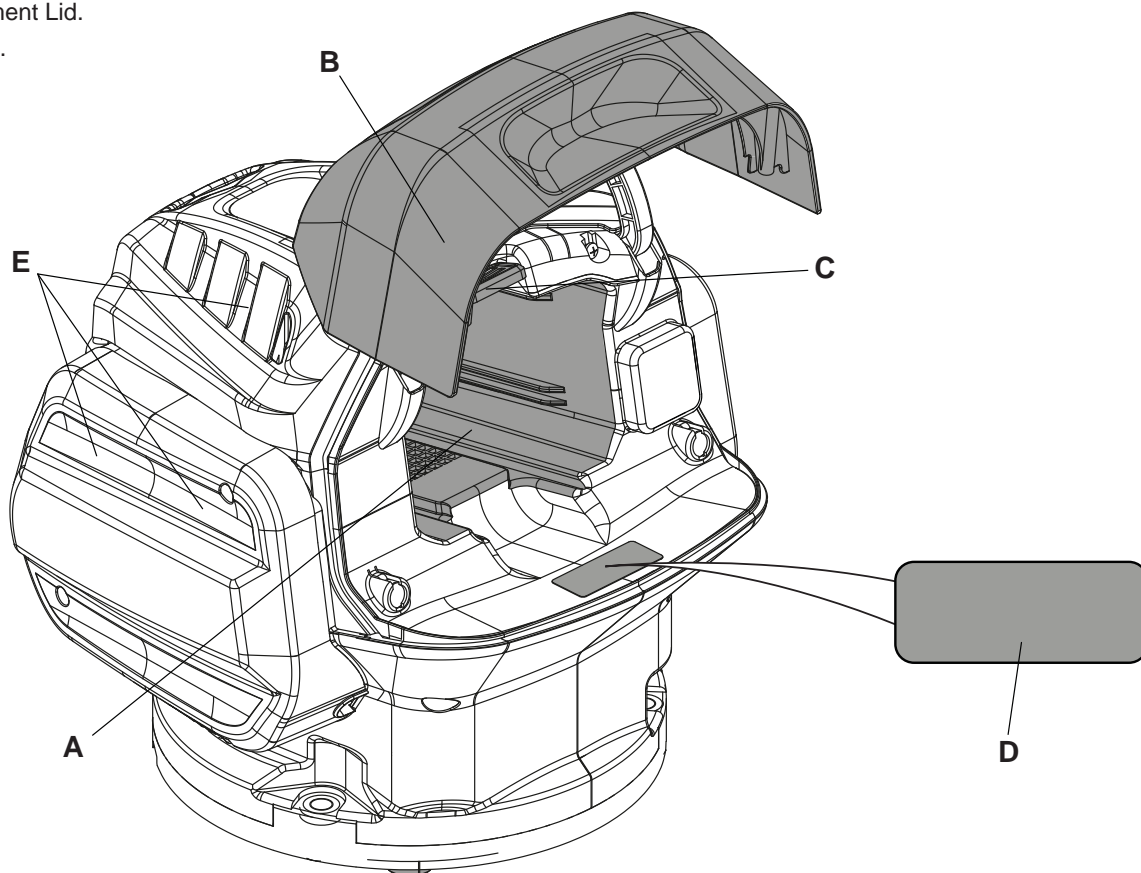

## BATTERY PACK COMPONENTS

- A. Battery Charge Level Button.
- B. Battery Charge Level Display.
- C. Serial Label.
- D. Battery Caution / Over Temperature Indicator

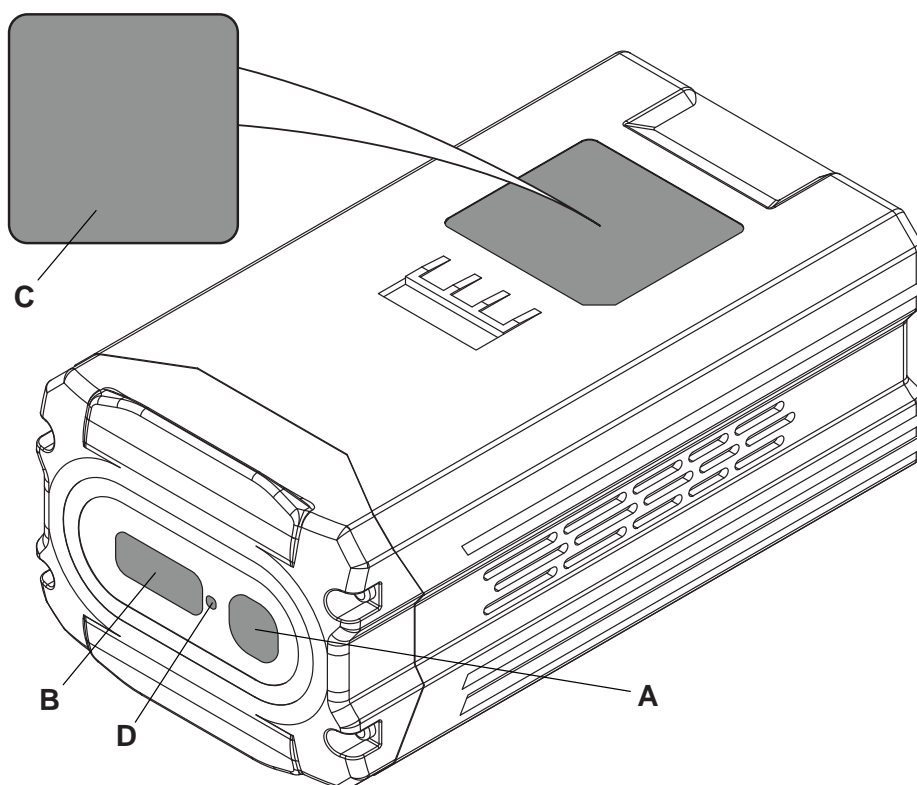

## BATTERY CHARGER

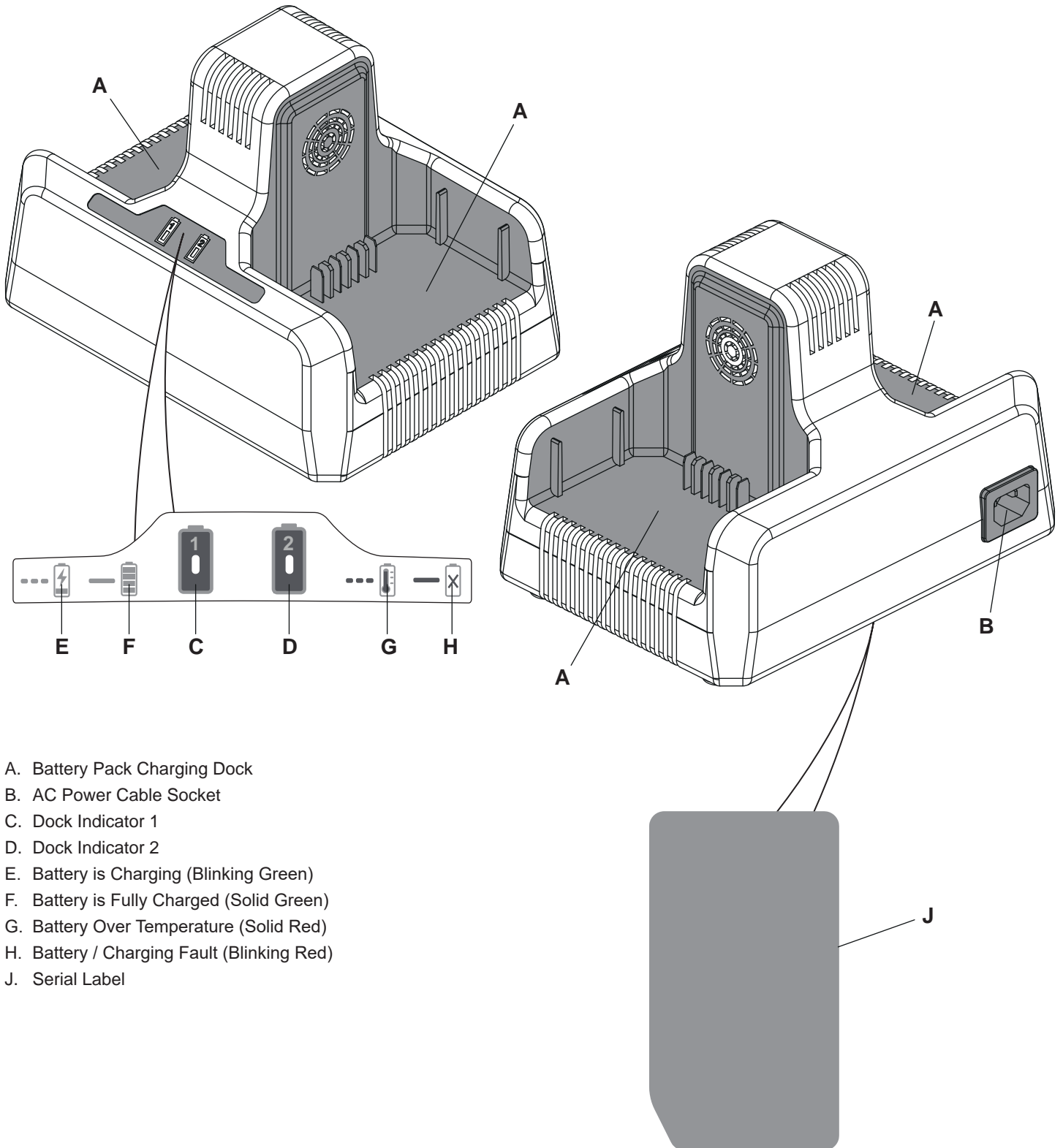

- A. Battery Pack Charging Dock
- B. AC Power Cable Socket
- C. Dock Indicator 1
- D. Dock Indicator 2
- E. Battery is Charging (Blinking Green)
- F. Battery is Fully Charged (Solid Green)
- G. Battery Over Temperature (Solid Red)
- H. Battery / Charging Fault (Blinking Red)
- J. Serial Label

## STATIC DIMENSIONS

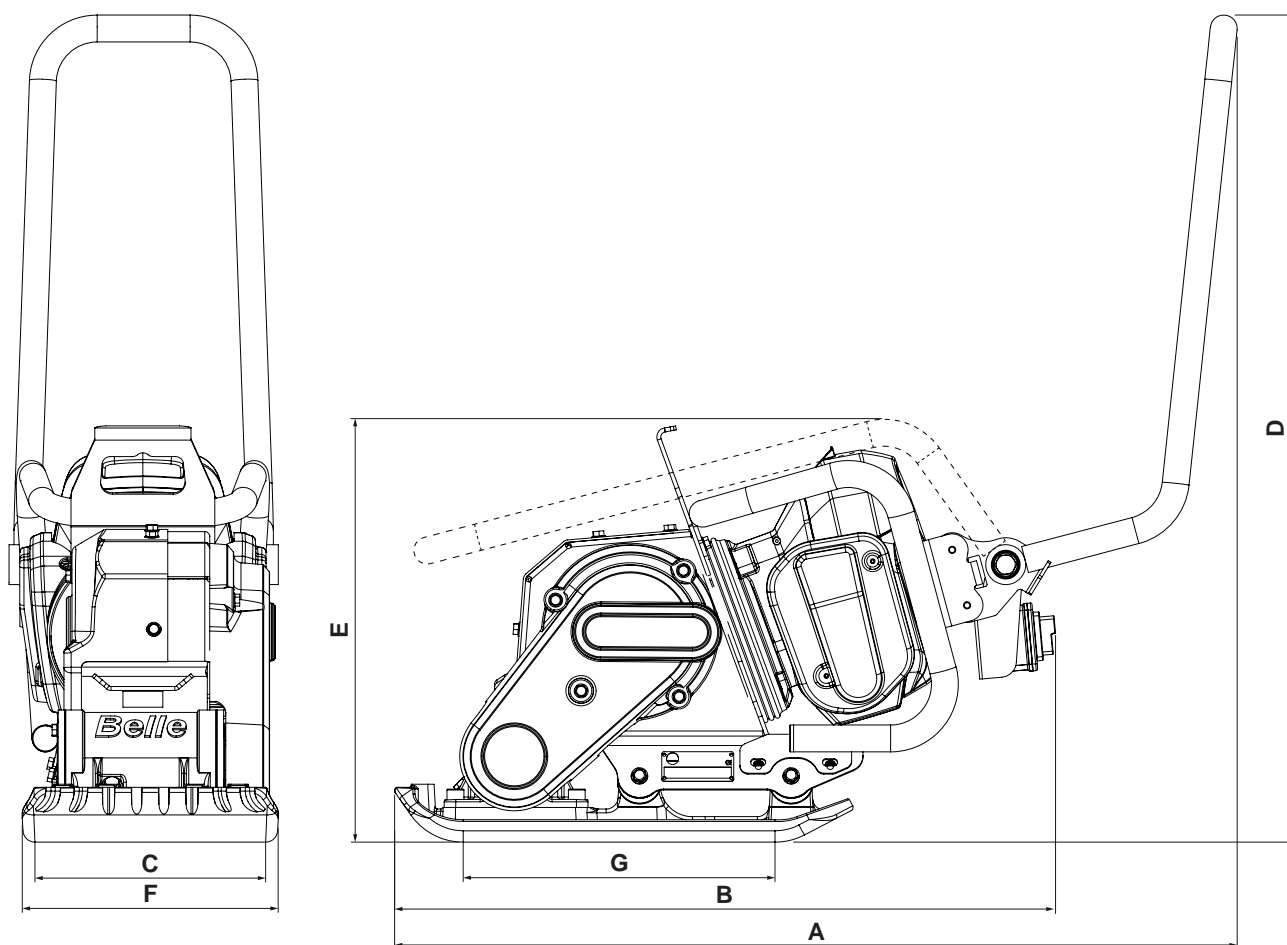

Model	PCLX 32E+	PCLX 32SE+	PCLX 40E+
A - Operating Length (mm)	1055	1055	1055
B - Storage Length (mm)	822	822	822
C - Width (mm)	320	320	400
D - Operating Height (mm)	1036	1036	1036
E - Storage Height (mm)	530	530	530
F - Plate Contact Width (mm)	289	289	369
G - Plate Contact Length (mm)	391	391	391

## GENERAL DATA

Model	PCLX 32E+	PCLX 32SE+	PCLX 40E+
Motor (Hp / kW)	2.0 / 1.5	2.0 / 1.5	2.0 / 1.5
Motor Type	Brushless	Brushless	Brushless
Motor RPM	2600	2600	2600
Vibrator Force (KN)	13	13	13
Frequency (Hz)	101	101	101
Static Pressure (kg/m <sup>2</sup> )	397	1800	337
Max. Gradient (°)	20	20	20
Max. Travel Speed (m/min)	20	TBC	20
*Vibration Level (m/s <sup>2</sup> )	< 2.5	< 2.5	< 2.5
Weight (kg)	57	66	62
Sound Power Level (dB(A))	105	105	105

## BATTERIES

Model	5Ah Battery	8Ah Battery
Battery Type	Li-Ion	Li-Ion
Weight (kg)	2.8	3.9
Dimensions L x W x H (mm)	120 x 90 x 214	120 x 90 x 240
Max. Voltage (v)	82	82
Nominal Voltage (v)	72	72
Energy Rating (Wh)	360	580
Energy Capacity (Ah)	5	8
80% Charge Time (Mins)	28	48
100% Charge Time (Mins)	39	65

## BATTERY CHARGER

Model	Battery Charger
Dimensions LxWxH (mm)	230 x 170 x 170
Weight (kg)	2.0
Input Voltage AC (v)	230v
Input Frequency (Hz)	50 / 60
Output voltage DC (v)	82
Output current (A)	8

## GENERAL SAFETY

For your own personal protection and for the safety of those around you, please read and ensure you fully understand the following safety information. It is the responsibility of the operator to ensure that he/she fully understands how to operate this equipment safely. If you are unsure about the safe and correct use of the machine, consult your supervisor or Altrad Belle.



### **WARNING**

*Improper maintenance can be hazardous. Read and Understand this section before you perform any maintenance, service or repairs.*

This machine is designed to eliminate the possible risks arising from the use of it. However, risks **DO** reside, and these residual risks are not clearly recognizable, and may cause personal injury or property damage, and possible death. If such unpredictable and unrecognizable risks become apparent, the machine must be stopped immediately, and operator or his supervisor must take appropriate measure to eliminate such risks. It is sometimes necessary that the manufacturer must be informed of such event for future counter measuring.

**ALWAYS** keep the Operator's Manual and any other manuals that accompany this machine to hand. Immediately replace any manuals that may have been lost or are now illegible.

## PRE-START CHECKS

The following Pre-start-up inspection must be performed before the start of each work session or after every four hours of use, whichever is first. Please refer to the service section for detailed guidance. If any fault is discovered, the machine must not be used until the fault is rectified.

1. Thoroughly inspect the machine for signs of damage. Check components are present and secure.
2. **ENSURE** there is no debris or excessive dirt present on the machine.
3. **DO** replace any worn/damaged warning decals.
4. **ENSURE** the battery pack is securely attached to power unit and the power cable is connected.
5. **ENSURE** the battery pack is sufficiently charged.
6. **DO NOT** use the battery if it shows signs of damage/ wear or if it is leaking fluid. In this case place the battery in a secure location away from flammable materials and arrange for safe disposal

Once all the above checks have been made, test run the machine checking that all switches function correctly and all indicators light when the power unit is turned on.

## WORKSITES

- **ENSURE** the operator is familiar with the working surroundings. Worksites can be hazardous.
- **ALWAYS** keep the work area tidy and clear of any obstructions that may lead to accidents and/or injuries.
- Cordon off the work area and keep members of the public and unauthorized personnel at a safe distance.
- This machine is heavy and must not be lifted single-handedly, either **GET HELP** or use suitable lifting equipment. A Wheel Kit Transport option is also available for this machine (see our website [Altrad-Belle.com](http://Altrad-Belle.com))

## OPERATING THE MACHINE

- **ENSURE** the operator has had adequate training prior to use, is familiar with all controls and knows how to safely switch the machine **OFF** before it is switched **ON** in case you get into difficulty.
- Suitable PPE **MUST** be worn when using this equipment i.e. Safety Goggles, Gloves, Ear Defenders, Dust Mask and Steel Toe capped footwear (with anti-slip soles for added protection). Wear clothing suitable for the work you are doing and **DO NOT** wear loose jewellery that could be caught in moving parts
- **ALWAYS** inform colleagues of what you will be doing and where you will be working.
- **DO NOT** operate the machine when you are ill, feeling tired, or when under the influence of drugs / alcohol.
- **NEVER** leave the power unit running and unattended.
- **NEVER** remove or tamper with any guards fitted, they are there for your protection. Always check guards for condition and security, if any are damaged or missing, **DO NOT USE THE MACHINE** until the guard has been replaced or repaired.
- When working on a gradient **ALWAYS** work up and down the slope, not across.
- **ALWAYS** proceed with caution when working around utilities (gas, water pipes electrical lines)
- **ENSURE** extra care is taken when working near to banks or trenches where there is a danger of the material collapsing.
- When working within trenches or pits **ALWAYS** pay attention to the side walls as the vibration from the machine could cause them to collapse.
- Some vibration from the compaction operation is transmitted through the handle to the operator's hands. The Altrad Belle Plate Compactor range has been specifically designed to reduce hand/arm vibration levels. Refer to the Technical Data section for vibration levels and usage times (recommended maximum daily exposure time). **DO NOT** exceed the maximum usage times.

## OPERATING THE MACHINE CONT.

- The compacting process will occasionally produce dust, which may be hazardous to your health. Always wear a mask that is suited to the type of dust being produced.
- Check for visible damage to the ON/OFF button and housing. If damaged **DO NOT** operate the machine and arrange for repair.
- If your machine catches fire, use a dry powder or CO2 fire extinguisher to put out the fire. If the fire can not be put out, keep away and call the fire brigade. If you are in any doubt about the safety condition of your machine, please contact Altrad Belle or your local authorised dealer.

### **When Operating the Compactor**

- Keep unauthorised persons & animals away.
- **DO NOT** use the battery charger outdoors.
- **DO** only use the approved batteries to operate this machine.
- **DO** only use the approved chargers to charge the batteries for this machine.
- **DO NOT** expose the motor power unit to excessive amounts of water or pressurised jets of water.
- **ALWAYS** close the protective covers on the machine when in operation or stored outside.
- **DO NOT** obstruct any ventilation holes or vents
- **DO NOT** operate the machine in explosive atmospheres, such as in the presence of flammable liquids, gases or dusts
- **ALWAYS** remove the battery when storing or transporting the machine.
- **AVOID** damaging the motor housing. **DO NOT** drop or rest the machine onto its motor housing. **DO NOT** rest heavy or sharp objects on the housing during storage or transportation.
- **DO** keep batteries away from other metal objects when storing or transporting them. Keys, tools, nails, screws and other small metal objects could cause a short circuit between the battery terminals. This could result in burns, fire or battery damage.
- **DO** maintain the machine in good working order. Clean regularly and ensure all covers, guards & warning decals are in place. Clean the machine with a stiff non-metallic brush and a damp cloth with mild soap. **DO NOT** use solvents or harsh chemicals for cleaning non-metallic parts of the machine. These chemicals may weaken the materials. **DO NOT** immerse parts in water or allow water to enter the vents and openings of the motor housing.

## BATTERY PACK

- **ALWAYS** use a genuine battery pack that is intended for this machine.  
**DO NOT** touch the Battery Pack's connectors with metal objects or insert metal objects through openings into the Battery Pack.
- **ALWAYS** keep the battery pack clean and dry.
- **NEVER** allow the battery pack to come into contact with water.
- If the Battery Pack leaks fluid or smells strangely, **IMMEDIATELY** move it away from any heat sources or flame. There is a risk of fire or rupturing if the leaked liquid or gas ignites.
- The Battery Pack contains combustible organic solvents as an electrolyte solution. If the liquid gets into your eyes, rinse them with plenty of water. After that, **IMMEDIATELY** seek medical care.
- **DO NOT** allow children to use the Battery Pack. Store the Battery Pack out of the reach of children.
- **DO NOT** store the Battery Pack in a damp location. Doing so can cause a malfunction.
- When the Battery Pack is not in use, keep it away from other metal objects, like paper clips, coins, keys, nails, screws or other small metal objects, that can make a connection from one terminal to another. Shorting the battery terminals together may cause burns or a fire.
- In case of fire, **STOP** using the machine immediately and extinguish with dry chemical, sandy soil, carbon dioxide or appropriate foam.
- The Battery Pack will deteriorate if it is repeatedly charged and discharged, as well as if it is stored and not used.
- As the Battery Pack deteriorates, its full-charge capacity decreases and the length of time it can be used shortens. Once the full-charge capacity is reduced by deterioration, it cannot be recovered and cannot reach the charging capacity of a new Battery Pack.
- **ALWAYS** remove the battery pack from the power unit when carrying or checking it.
- **ONLY** charge the battery pack in a recommended charging unit.
- **DO NOT** expose the battery pack to extreme temperatures (below 5°C (41°F) or above 40°C (104°F))
- **NEVER** attempt to service a damaged battery pack.
- **WORK ON THE BATTERY PACK OR POWER UNIT MUST ONLY BE CARRIED OUT BY QUALIFIED PERSONNEL.**
- **DO NOT** subject the Battery Charger to excessive physical shock, such as by dropping or hitting it.
- **DO NOT** use the Battery Charger to charge anything except Honda Battery Packs. Use only authentic Battery Packs. Charging a non-authentic Battery Pack could damage it and the charger because of poor protection functions, etc.
- **DO NOT** touch the Battery Pack terminals with metal. Mishandling them could result in electric shock or fire, which may kill or seriously hurt you. Follow the procedures and instructions provided in the manufacturers manual.

## **BATTERY CHARGER**

- To reduce risk of injury, charge **ONLY DP72104Z** type rechargeable batteries. Other types of batteries may burst causing personal injury and damage.
- This Battery Charger is not intended for use by children or persons with physical, sensory or mental limitations or a lack of experience or knowledge. **DO NOT** allow children to play with this Battery Charger - **IT IS NOT A TOY!**
- Charge only Li-ion Honda Battery Packs that have a capacity of 10 Ah with 80 battery cells. The battery voltage must match the battery charging voltage of the Battery Charger. **DO NOT** charge non-rechargeable Battery Packs, otherwise there is danger of fire and explosion.
- Continued use of the Battery Charger under unusual conditions could result in fire or electric shock, which may kill or seriously hurt you.
- **DO NOT** modify the Battery Charger. Modifying, disassembling or repairing the Battery Charger could result in fire or electric shock, which can cause death or serious injury. Disassembly and repairs require specialized knowledge, contact your servicing dealer.
- Before using the Battery Charger / charging a Battery Pack, people who are using an electronic medical device must confirm how their device might be affected. The electromagnetic radiation produced during charging may affect the operation of electronic medical devices, which may kill or seriously hurt you.
- If the Battery Pack leaks fluid or smells strangely, stop using it and contact your servicing dealer. Battery Pack contains combustible organic solvents as an electrolyte solution. Mistakenly handling them may result in burns or serious injuries.

**DO NOT** use the Battery Charger in the following situations.

- Locations where the Battery Charger becomes unstable.
- Locations where there is flammable gas or combustible materials
- Locations that are very cold or very hot, such as in direct sunlight or near a heater
- Locations exposed to water or excessive humidity
- Locations where children or pets might play with it

**ALWAYS** follow the rules below.

- **DO NOT** charge Battery Packs if there is the risk of a lightning storm.
- **DO NOT** charge if the electric outlet is loose.
- **DO NOT** charge if the Battery Charger, AC cable, or the electric outlet is damaged or deformed, dusty, dirty, or rusty.
- **DO NOT** plug too many power cords into one electric outlet.
- **DO NOT** charge while the AC cable is wound up.
- **DO NOT** stand on or place heavy objects on the Battery Charger or AC cable.
- **DO NOT** pull or repeatedly bend the AC cable or charging cable with an excessive force.
- **DO NOT** touch the Battery Charger or AC cable if your hands are wet.
- **DO NOT** splash or submerge the Battery Charger or AC cable in water.
  - If the Battery Charger or AC cable is submerged in water while you are charging, do not touch the Battery Charger or AC cable. Contact your servicing dealer.
- **DO NOT** leave the AC plug plugged into the electric outlet after you finish charging.
- **DO NOT** pull on the cable when you pull out the AC plug.
- **DO NOT** subject the Battery Charger to excessive physical shock, such as by dropping or hitting it.
- **DO NOT** use the Battery Charger to charge anything except Honda Battery Packs. Use only authentic Battery Packs. Charging a non-authentic Battery Pack could damage it and the charger because of poor protection functions, etc.
- **DO NOT** touch the Battery Pack terminals with metal. Mishandling them could result in electric shock or fire, which may kill or seriously hurt you. Follow the procedures and instructions provided in the manufacturers manual.

## WEATHER CONDITIONS

- We recommended that this machine not be used in heavy rain.
- Rain can alter the condition of the worksite surface area. **ALWAYS** be aware of the condition of the surface after it has rained.
- Operating the machine in poor visibility can result in serious injury or even death. **ALWAYS** use your lights to improve the visibility of the area.
- **NEVER** operate the machine in temperatures below 5°C (41°F) or above 40°C (104°F)

## DURING MAINTENANCE

- **ALWAYS** remove the battery before carrying out any maintenance on the machine.
- Carry out maintenance and repair work only if the machine is positioned on stable and level ground and has been secured against inadvertent movement.
- **NEVER** service the machine while the power unit is running, always switch **OFF**.
- Clean the machine, especially connections and threaded unions, before carrying out maintenance/repair.
- When dismantling assemblies containing components under pressure from springs, always wear suitable PPE. This will protect against eye injuries from accidental flying components.
- When handling oil, grease and other chemical substances, observe the product related safety regulations.

## AFTER MAINTENANCE

- **ALWAYS** tighten any screwed connections that have been loosened during maintenance and repair.
- Any safety devices removed for set-up, maintenance or repair purposes must be refitted and checked immediately upon completion of the maintenance and repair work.
- **ENSURE** that all consumables and replaced parts are disposed of safely and with minimum environmental impact.

## MODIFICATIONS & REPLACEMENT PARTS

- **NEVER** make any modifications or additions to the machine without the prior approval of Altrad Belle. Any unapproved modifications may affect the performance and safety of the machine. This may also void the Warranty.
- **ALWAYS** use genuine Altrad Belle replacement parts. Use of non-genuine replacement parts may affect the performance and safety of the machine. This may also void the Warranty.

Genuine Altrad Belle replacement parts can be purchased online at [www.Altrad-Belle247.com](http://www.Altrad-Belle247.com)

## SAFETY DECALS

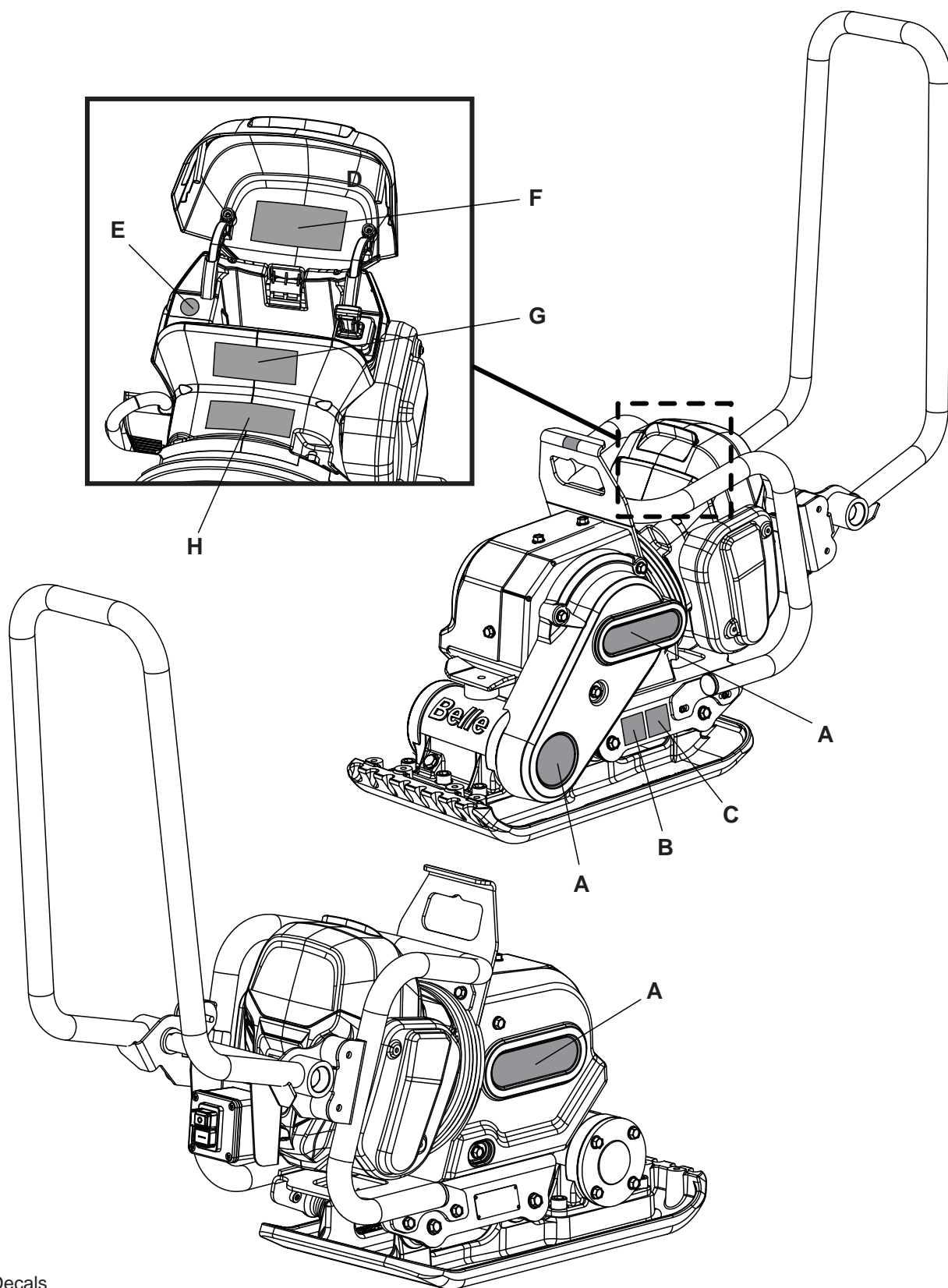

- A. Branding Decals
- B. Lifting Point Decal
- C. Safety Decal.
- D. Noise Decal.
- E. No Jetwash Decal.
- F. Battery Removal Decal.
- G. Cover Removal Decal.
- H. Motor Rating Deca.

## SAFETY DECALS

### A - Branding Decals

### B - Lifting Point Decal

Lifting point for use with a Sling or Mechanical Hoist.

### C. Safety Decal.



**Read the  
Operators  
Manual**



**Wear Ear  
Protection**



**Wear Eye  
Protection**



**Wear Protective  
Footwear**

### D - Noise Decal

Indicates the Noise Level of the machine during operation.

### E - NO Jetwash Decal

**DO NOT** use a jetwash to clean this machine under any circumstances.



**DO NOT  
Jetwash the  
Machine**

### F. Battery Removal Decal.

Shows the correct procedure for removing the battery from the power unit.

1. Push down lightly onto the top of the battery with the palm of your hand.
2. Whilst still pushing down, press and release the battery retaining latch with the fingers of the same hand. Remove your hand from the top of the battery and it should rise slightly.
3. Grip the top of the battery with one hand across the 2 short faces.
4. Lift the battery slowly. Once the battery slides halfway out of the housing grip the middle of the battery with the second hand.

### G. Cover Removal Decal.



**WARNING** The battery **MUST** be removed from the power unit **BEFORE** any protective covers are removed.

### H. Motor Rating Decal.



**Read the  
Operators  
Manual**



**Electrical  
Hazard!**

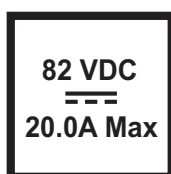

**Nominal  
Voltage**

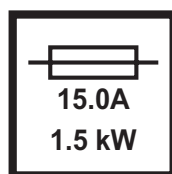

**Nominal  
Current &  
Nominal  
Power**



**Motor RPM**

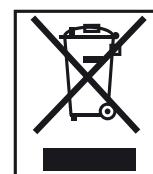

**WEEE Icon**



# Operating Instructions

## REASONS FOR COMPACTION

Soil, which has been disturbed or new infill, subbase and blacktop, will have small voids or air pockets which, if not compacted, will lead to one or more problems occurring.

1. As traffic crosses the surface of an uncompacted area, the material is compressed. This leads to subsidence of the top surface as the material fills the voids.
2. A similar situation occurs with static loads on uncompacted ground. The load (e.g. a building) will sink.
3. Materials with voids are more susceptible to water seepage, leading to erosion. Water ingress may also cause the soil to expand during freezing temperatures and contract during dry spells. Expansion and contraction is a major cause of damage to building foundations and normally leads to the structure requiring underpinning.  
Compaction increases the density of the material and therefore increases its load bearing capacity. Reduces air voids and therefore reduces the risk of subsidence, expansion and contraction, due to ingress of water.

## APPLICATIONS

Applications/materials fall into three categories:

1. Cohesive materials (less than 20% granular) e.g clay, silt & heavy soils.
2. Granular materials (more than 20% granular) e.g hard core, sand & light soils.
3. Bituminous materials e.g asphalt (tarmac), cold lay (bitumin emulsion products).

The chart shows the HAUC specifications for layer depth and number of passes for Dual Force' plates. If standard machines are used, optimum compaction can not be guaranteed, however, if layer depths are reduced and number of passes increased, results can be improved.

Moisture content of cohesive & granular materials is critical to effective compaction. If granular material is too dry it will flow around the plate instead of compacting. If the moisture content is too high the material may dry out after compaction and shrinkage will occur.

1400 - 1800 kg/m <sup>2</sup>	COMPACTION PASSESS REQUIRED PER LAYER OF COMPACTED THICKNESS UP TO.				
	40mm	60mm	80mm	100mm	150mm
<b>Cohesive Materials**</b>	2**	4**	5**	6**	Reduce Layer Thickness
<b>Granular Materials</b>	2*	3*	4*	<b>5</b>	9
<b>Bituminous</b>	6	10	12		Reduce Layer Thickness

\* Usually placed in 100mm minimum layer so not specified by HAUC.

\*\* The nature of cohesive materials makes plate compaction difficult. Optimum compaction is not guaranteed and not recommended by HAUC.

## COMPACTION SPECIFICATION

Various methods have been employed in the past to specify the compaction required for various applications. The factors to consider are, material properties, layer thickness, pressure applied, vibration and number of passess. Greater understanding of how compaction works has led to new compaction specifications being introduced. The most up to date specification is part of the U.K.'s NRSWA (New Roads & Street Works Act). Civil Engineers are now adopting these specifications to ensure good compaction for all site work.

### **NRSWA (HAUC specification).**

The specification was compiled by HAUC (Highways Authorities & Utilities Committee). The 'New Roads and Street Works Act 1991, set a new standard for road repairs and reinstatements in the UK. It covers materials, methods, equipment and safety when carrying out reinstatements on roads and footways. The reason for the act is to ensure repairs and reinstatements are carried out to a higher standard and ultimately last longer. This in turn will reduce the need for costly remedial work and reduce traffic delays.

There are two categories specified for plate compactors.

1. 1400 to 1800kg/m<sup>2</sup>
2. Over 1800kg/m<sup>2</sup>

These figures relate to the static pressure applied by the machine

NOTE: No standard single direction plate compactors comply with this minimum specification. For highways work always use a 'Dual Force' plate compactor.

### **DUAL FORCE**

Altrad Belle studied the act then developed equipment to enable contractors to comply with the act's requirements. The NRSWA legislation requires that compaction equipment meets the minimum specification. By purchasing an Altrad Belle 'Dual Force' plate, you are immediately complying with this part of the act. To comply with the specification and maintain surface tolerance, Altrad Belle 'Dual Force' base plates are divided into two areas providing two stages of compaction.

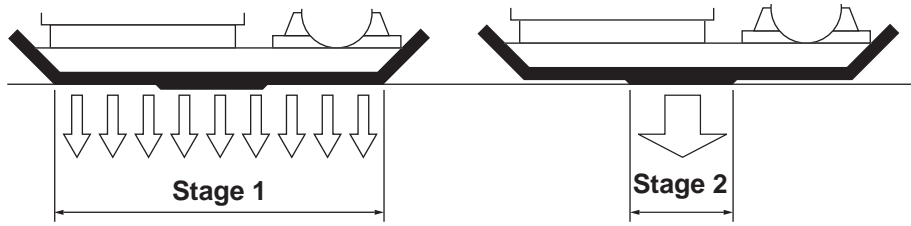

- Stage 1:** The full base area compacts the material like a standard machine.  
**Stage 2:** The base rises onto the 'Dual Force' section to give 3 to 4 times the compaction force of standard plates.

Refer to the Machine Description section to identify all components mentioned in this section.

## CHARGING THE BATTERY PACK

**CAUTION** *The battery pack is not shipped fully charged. It is recommended to fully charge before use to ensure that maximum run time can be achieved.*

1. Plug the charger into an AC power outlet.
2. Insert the battery pack into the charger.

The approved charger is a diagnostic charger. The charger LED light will illuminate in specific order to communicate the current battery status. They are as follows:-

LED Status	Blinking Green	Solid Green	Solid Red	Blinking Red
Description	Charging	Fully Charged	*Over Temperature	*Charging Fault

\* Refer to the Troubleshooting Guide.

## INSERTING THE BATTERY PACK

1. Select a compatible battery and check that it is in good operational condition. If the battery shows signs of impact damage, emits an unusual smell, feels hot **DO NOT USE**
2. Check the charge value by pressing the 'charge indicator' button. If the battery charge is sufficient then proceed to insert the battery into the motor housing.
3. Open the battery cover on the power unit.
4. Hold the battery with 2 hands. One hand should grab the battery from the top with the charge display facing upwards, gripping it across the 2 short sides. The second hand should hold the battery around the middle.
5. Turn the battery until the retaining lug lines up with the battery retaining clip.
6. Slide the base of the battery into its housing locating the slide rails.
7. Remove your hand from the middle keeping hold of the battery from the top and allow the battery to slide fully into the housing.
8. Once fully inserted, press lightly down on the top of the battery until the battery retaining latch, clicks into position and locks the battery in place.
9. Close the battery cover and the top cover lid.
10. The mixer is now ready for operation.

## EMERGENCY STOP

If you have to turn off the machine in an emergency you must: Press the **RED STOP** button. In the case of a Stop button failure the machine can be stopped by removing the battery.

## STOPPING THE POWER UNIT

1. Press the red **STOP (O)** button at the rear of the machine and the power unit will stop.

## STARTING THE POWER UNIT

1. Press the green **START (I)** button at the rear of the machine and the power unit will start.

## REMOVING THE BATTERY PACK



**CAUTION** ENSURE the machine is switched **OFF** before removing the battery.

1. Stop the machine using the stop button.
2. Open the battery cover.
3. Push down lightly onto the top of the battery, at the same time press and release the battery retaining latch. Remove your hand from the top of the battery and it should rise slightly.
4. Then grip the top of the battery with one hand across the 2 short faces and lift slowly.
5. Once the battery slides halfway out of the housing grip the middle of the battery with the second hand.
6. Lift the battery from the battery housing.
7. If the battery needs to be charged then carefully move it to the battery charger.
8. If the battery is to be stored then place the battery in a dry place away from direct sunlight or excessive temperatures. It is recommended to store the battery at between +6°C to +40°C.
9. If the battery is to be transported it should be placed into protective packaging or storage (see local regulations for the transportation of Li-ion batteries)

**NOTE: DO NOT** transport the machine with the battery fitted. This could lead to the battery being damaged due to knocks & shocks, vibrations, or exposure to the weather and elements.

10. Leaving the battery fitted to the machine during transportation may also lead to the high value battery being stolen.
11. See also the manufacturers instruction card supplied with the charger.

## CHECKING THE CHARGE LEVEL OF THE BATTERY PACK

Push the red battery charge level button (See adjacent image) on top of the battery whilst it is inserted into the power unit and the power level will show on the digital display in numerical format.

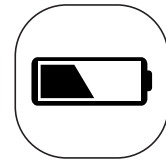

## BATTERY CHARGING

- Only charge compatible batteries with the charger.

**NOTE: ALWAYS** allow the battery to complete 5 charge cycles (A cycle is defined as 100% - 0% - 100%) to enable the battery to reach its optimum capacity

1. Plug the power lead into the charger body.
2. Connect the power lead plug into a suitable rated mains power supply socket.

**NOTE:** This charger should only be used on 230v AC 50/60Hz supply with a minimum load current of 10A

3. Use the battery charger indoors only and away from any damp environments.
4. Place the charger on a flat surface and do not obstruct any ventilation slots.
5. Do not use the charger in any explosive atmospheres and keep away from combustible powders, water sprays or metallic dust or shavings.
6. Slide the battery into the slot of the charger ensuring that the battery contacts are aligned with the charging connection blades.
7. Gently push the battery firmly into the charger slot.
8. Switch the power outlet on.
9. Check the indicator LED (C or D).

**Flashing Green** = Charging (Leave battery on the charger until LED shows solid Green)

**Solid Green** = Battery charged (Battery charged, remove battery from charger)

**Solid Red** = Battery over temperature [Battery caution logo] (Leave the battery on the charger for up to 30mins until the LED flashes Green)

**Flashing Red** = Battery fault (Remove battery and dispose of correctly)

10. The battery will only start charging if the charge level is below 69%.

- See also the manufacturers instruction card supplied with the charger.

## TRANSPORTATION



### **CAUTION**

We **RECOMMEND** removing the battery pack from the power unit before transporting the machine.

Transporting the machine is a 2 person operation. Use the provided Hand Lifting Points (See Machine Description section) **DO NOT** use a Mechanical Hoist on the Hand Lifting Points.

Where it is necessary to use lifting equipment to transport the machine, make sure the lifting equipment has a WLL (Working Load Limit) suitable for the machines weight (see Technical Data section). Attach suitable chains or slings **ONLY** to the lifting point on the top of the machine.

If using the optional Wheel Kit attachment the handle latch must **ALWAYS** be engaged using the following procedure.

1. Pull the plunger and rotate the latch clock wise until it locates over the handle tube. Release the plunger to lock the latch in the lock position.

The Wheel Kit can now be fitted as per the instructions provided with the Wheel Kit. Then tilt the machine forward to raise the transport wheels off the ground and underneath the baseplate. Then slowly lower the machine on top of the wheels.

To disengage the handle latch when the Wheel Kit is not in use, use the following procedure:-

1. Pull the plunger and rotate the latch anti-clock wise to its stop position. Release the plunger to lock the latch in the unlock position.



### **CAUTION**

**ALWAYS** pull the machine backwards when using the optional Wheel Kit attachment.

## OPERATING THE MACHINE

Having carried out the Pre-Start Checks listed in the Safety Instructions section of this manual, you may start the power unit.

The vibrator will not only cause the baseplate to vibrate but will also cause the machine to travel forward. During normal operation you should not have to push the machine forwards but allow it to travel at its own pace. The speed of travel will be determined by the condition of the surface being compacted.

If the surface to be compacted is on a slope, great care must be taken when controlling the machine's direction of travel. If necessary, use a suitable rope attached to the machine at a low point on the chassis, to allow a helper to take part of the machine's weight. Work up and down a slope not across.

Work the compactor over the surface in an organised pattern until the required compaction has been achieved. Where there are a number of different layers to be compacted on top of each other, compact each layer individually.



## Storage

If the machine is not to be used for an long period of time it must be stored correctly to prevent deterioration or damage occurring during this period.

Store the machine in a clean dry building with plenty of ventilation if possible. If you can only store outdoors, cover with a waterproof sheet / tarpaulin.

### PREPARING THE MACHINE FOR STORAGE

1. Clean the machine and remove all unwanted material / debris (See the Cleaning section of this manual).
2. Dry the machine to remove any moisture.
3. Apply grease to any moving parts / grease points.
4. Examine the machine for any worn / damaged parts. Replace if necessary.

### STORING THE MACHINE

1. Place the machine safely on stable, level ground.  
**ENSURE** there is sufficient room around the machine to be able to carry out any service or maintenance procedures during the storage period.
2. **ENSURE** the battery pack is removed and stored in a clean, dry area.

### DURING STORAGE

To prevent the build up of rust and to minimise the risk of seizures, periodically operate all machine functions during storage.

1. Install a fully charged battery.
2. Start the power unit.
3. Operate the machine to **ENSURE** it operates correctly.
4. Re-do storage procedure from above.

### REMOVING THE MACHINE FROM STORAGE

1. Install a fully charged battery.
2. Carry out the Pre-Start Check procedure.
3. Operate the machine as per the operating instructions in this manual.



## Environment



### Safe Disposal.

Instructions for the protection of the environment.

The machine contains valuable materials.

Take the discarded apparatus and accessories to the relevant recycling facilities.

Component	Material	Component	Material
Handle	Steel	Power Unit	*See Below
Belt Guard	HDPE	Battery Pack	*See Below
Motor Housing	Aluminium	Battery Charger	*See Below
Main Frame	Steel	Flexible Mounts	Steel and Rubber
Baseplate	Steel	Various Parts	Steel and Aluminium
Vibrator Housing	Aluminium	Water Bottle (If fitted)	Plastic
Eccentric Weights	*See Below	Water Bottle (If fitted)	Plastic

**\*DO NOT** dispose of electric equipment together with household waste material.

If electrical appliances are disposed of in landfills or dumps, substances can leak and react and enter into the foodchain, damaging your health and well-being. For further information on the disposal of this product, please contact your dealer or your nearest domestic waste collection service.

## GENERAL

This machine is designed to give many years of trouble free operation. It is, however, important that the simple regular maintenance listed in this section is carried out. All maintenance procedures must be carried out by a competent, suitably qualified person.

A poorly maintained machine could be a danger to the operator and the other personnel on the worksite. **ENSURE** that the regular maintenance procedures listed in this manual are performed correctly and on time to keep the machine safe and efficient.

**ALWAYS** use genuine Altrad Belle replacement parts, the use of spurious parts may void your warranty.

Before any maintenance is carried out on the machine, switch off the machine and **ALWAYS** set the machine on stable, level ground.

**ENSURE** any faults identified during maintenance procedures are addressed and corrected immediately.



### **WARNING**

*Before starting any maintenance or repairs, switch off the motor and remove the battery. On completion of maintenance, check that the mixer functions correctly and that all guards are correctly fitted.*

## CLEANING

Keeping the machine clean is an integral part of the service and maintenance program. The build-up of mud, dirt and debris could potentially affect the operating safety of the machine, exposing both the operator and other personnel to potentially hazardous situations.



### **WARNING**

*NEVER use a hose or pressure washer to spray water on the machine while cleaning it. Water entering the power unit components may cause a malfunction and/or injury.*

**ALWAYS** clean the machine using compressed air and wipe the battery pack clean with a dry, clean cloth. Before cleaning the Battery Pack, remove it from the specified device or the Battery Charger.

After the cleaning process check that all cables, hoses and fasteners are in place and secure. Replace any if necessary. Also **ENSURE** that all safety / warning decals are present in their correct locations. Replace any if necessary.

## VIBRATOR UNIT

Place the machine safely on stable, level ground. Remove the plug complete with seal, check that the oil level reaches the bottom thread on the oil plug hole. Top up as necessary with the correct oil (see chart below).

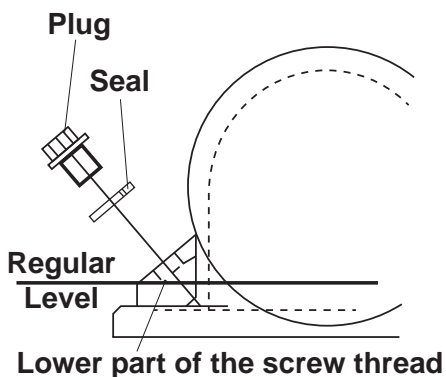

Component	Oil Type	Quantity
Vibrator	SAE 10 W 40	0.22 Litres

## POWER UNIT & OPERATION

Problem	Cause	Remedy
The power unit does not start.	The battery is not fully inserted.	Check the connection between the battery and the battery port. <b>ENSURE</b> the battery clicks into place.
	The battery is not charged.	Charge the battery.
	The main fuse may have blown.	Isolate the power supply by removing the battery. Remove the side cover and locate the main fuse in the wiring harness. Check the fuse and replace it if necessary.
	The Start / Stop button is faulty	*Fault find the switch and replace if necessary
	Battery may require service or replacement.	Replace the battery.
The power unit is excessively noisy and vibrates.	The motor shaft is bent.	Stop the power unit and inspect for damage.
The machine stops during operation and an alarm can be heard.	The motor has been overloaded.	Press the Stop button and leave the machine to cool for 3-4 minutes. Then restart the machine by pressing the Start button.
Machine will not vibrate.	Power Unit speed too slow.	Contact agent or Altrad Belle.
	Drive belt tension loose.	Adjust belt tension.
	Drive failure.	Contact Agent or Altrad Belle.
	Vibrator failure.	Contact Agent or Altrad Belle.
Asphalt adhering to plate.	Lack of lubrication.	Use a water spray system.
Paving blocks damaged.	Plate in direct contact with material.	Use a paving pad.
Bituminous surface flaking (laminating).	Over compaction.	Remove and relay.
Low travel speed (plate sinking).	Layer thickness too deep.	Remove some of the material.
	Moisture content too high or too low.	Remove material and adjust.

Items marked with \* should only be carried out by a competent electrician or Altrad Belle dealer.

## BATTERY PACK & CHARGER

Problem	Cause	Remedy
Charging does not start.	The AC plug is not connected to an electric outlet.	Connect the AC plug to an electric outlet correctly.
	The charging connector is not connected to the battery connector.	Connect the charging connector to the battery connector correctly.
	Charger may be too hot or too cold.	Move the charger and battery pack to a location where the ambient temperature is between 7°C and 40°C
Charging LED illuminates RED during charging.	Battery pack is too hot.	Remove the battery pack from the charger and allow to cool for at least 30 minutes. Re-insert battery pack once cool.
Charging LED flashes RED during charging.	Charging fault.	Remove the battery pack and unplug the charger. Wait 1 minute, plug the charger back in and re-insert the battery pack.
Charging LED still flashes RED during charging.	Faulty battery pack.	Replace battery pack. Dispose of faulty battery pack safely and correctly. See local guidance for advice on the safe disposal of Li-Ion batteries.

## 'Dual Force' / HAUC / NRSWA Certificate



When fitted with a 'Dual Force' base plate the Static Weight per Unit Area of this machine is over 1400 kg/m<sup>2</sup> and so complies with the NRSWA (HAUC specification) for plate compactors in the category 1400 – 1800kg/m<sup>2</sup>.

R. Neilson - *Managing Director*

'Dual Force' allows Altrad Belle plate compactors to be used for Highways reinstatements in accordance with the specifications stated in the NRSWA (New Roads and Streetworks Act 1991) Appendix A8.

Standard Altrad Belle plate compactors can be retro fitted with 'Dual Force', contact Altrad Belle for details.

## Warranty



Your new Altrad Belle 'PCLX E+' Single Direction Plate Compactor is warranted to the original purchaser for a period of one-year (12 months) from the original date of purchase. The Altrad Belle warranty is against defects in design, materials and workmanship.

The following are not covered under the Altrad Belle warranty:

1. Damage caused by abuse, misuse, dropping or other similar damage caused by or as a result of failure to follow assembly, operation or user maintenance instructions.
2. Alterations, additions or repairs carried out by persons other than Altrad Belle or their recognised agents.
3. Transportation or shipment costs to and from Altrad Belle or their recognised agents, for repair or assessment against a warranty claim, on any machine.
4. Materials and/or labour costs to renew, repair or replace components due to fair wear and tear.

The following components are not covered by warranty.

- Drivebelt/s

**Please also consult the Power Unit, Battery & Battery Charger manuals for further information on their warranty details.**

Altrad Belle and/or their recognised agents, directors, employees or insurers will not be held liable for consequential or other damages, losses or expenses in connection with or by reason of or the inability to use the machine for any purpose.

### Warranty Claims

All warranty claims should firstly be directed to Altrad Belle, either by telephone, by Fax, by Email, or in writing.

### For warranty claims:

Tel: +44 (0)1298 84606

Fax: +44 (0)1298 84073

Email: [warranty.dept@altrad-belle.com](mailto:warranty.dept@altrad-belle.com)

### Write to:

Altrad Belle Warranty Department, Sheen, Nr. Buxton, Derbyshire, SK17 0EU, GB.

### Warranty Registration:

In the bid for Altrad Belle to become greener and more eco friendly, we have now introduced online Warranty registration. To access the registration page of our website, please use the following address:-

[http://www.bellegroup.com/index.php?p=warranty\\_registration](http://www.bellegroup.com/index.php?p=warranty_registration)

Alternatively, please scan the adjacent QR Code (Quick Response Code) using your smartphone to access the registration page.

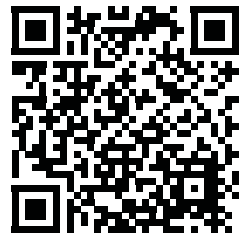

## Replacement Parts



When maintaining this product only the manufacturers original, genuine replacement parts may be used.

The user will lose any possible claims if replacement parts used are other than the makers original replacement parts.

Replacement parts for this product can be ordered online 24 hours a day, 7 days a week at [www.Altrad-Belle247.com](http://www.Altrad-Belle247.com)

For more information regarding the availability of replacement parts for this product, please contact Altrad Belle using the following contact details:-

Tel:- +44 (0)1298 84606

Fax:- +44 (0)1298 84073

Email:- [sales@altrad-belle.com](mailto:sales@altrad-belle.com)

Alternatively, please scan the adjacent QR Code (Quick Response Code) using your smartphone to access the Altrad Belle online parts portal.

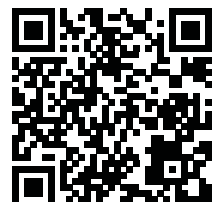



BELLE  
LIGHT  
CONSTRUCTION  
EQUIPMENT

### **Altrad Belle**

Sheen, Nr. Buxton, Derbyshire, SK17 0EU, GB

Tel. +44 (0)1298 84606 - Fax +44 (0)1298 84722 - Email: [sales@altrad-belle.com](mailto:sales@altrad-belle.com)

[www.Altrad-Belle.com](http://www.Altrad-Belle.com)

### **EU IMPORTER ADDRESS**

*ADRESSE DE L'IMPORTATEUR - DIRECCIÓN DEL IMPORTADOR - ENDEREÇO DO IMPORTADOR - ADRES IMPORTEUR  
IMPORTØRENS ADRESSE - IMPORTEUR ADRESSE - INDIRIZZO DELL'IMPORTATORE - IMPORTÖRENS ADRESS - IMPORTØRADRESSE  
MAAHANTUOJAN OSOITE - ADRES IMPORTERA - IMPORTIJA AADDRESS - IMPORTÉTĀJA ADRESE - IMPORTUOTOJO ADRESAS  
ADRESA DOVOZCE - ADRESA IMPORTATORULUI - IMPORTÓR CÍME - ADRESA UVOZNIKA - İTHALATÇI ADRESİ - ADRESA DOVOZCU*

### **Altrad Investment Authority SAS:**

150 Rue Le Pérugin, 34000 Montpellier, France

Tel. +33 (0) 4 67 50 53 66 - Email: [admin@altrad.com](mailto:admin@altrad.com)

[www.altrad.com](http://www.altrad.com)