



BELLE  
LIGHT  
CONSTRUCTION  
EQUIPMENT



Altrad-Belle.com

# PCX 13/40 E+



## BATTERY POWERED FORWARD PLATE COMPACTOR

Heavyweight, professional combination compaction plate designed with an emission free, Li-ion battery powered motor for all your compaction requirements, indoor usage and poorly ventilated areas.

Produces low HAV values and matches the high performance compaction of its petrol powered equivalent, but without the environmental impact...

...Building a Sustainable Future!



BUILDING A SUSTAINABLE FUTURE.

# PCX 13/40 E+

WE'RE **POSITIVE** YOU'LL LOVE IT!!

## FEATURES & BENEFITS

- Fitted with a robust, highly efficient brushless Honda eGX motor
- Lithium Ion battery, interchangeable with other Honda eGX powered Altrad Belle products.
- Environmentally friendly, emission free for use indoors & in poorly ventilated areas such as basements and tunnels.
- Low noise offers increased working hours and usage in noise restricted areas.
- High performance 13kN vibration unit gives excellent travel speed and compaction force, reducing operating times.
- Low operating HAV levels, gives more than 8hrs operator trigger time.
- Foldable mounted guide handle offers superior manoeuvrability and can be lowered to operate under obstacles and close to form work.
- Reinforced centrifugal clutch ensures longer belt life, and simplified belt adjustment.
- Single switch operation makes starting the power unit easy. No choke or recoil start.
- 3-speed selector, allowing slower speeds when working around obstacles.
- No routine power unit maintenance eliminates servicing or costly downtime due to repairs.  
no blocked carburettors
- Robust protective battery cover & steel sub frame. With integrated battery power level viewing window.
- Lifting points and front lift cage offer easier loading and unloading for operator convenience.
- Optional, large 9.5 litre water tank is built into the main frame for added protection.
- The spraybar is fully protected from damage, easily positioned, with integral paving pad clamp points.
- Angled holes on spray bar allow complete water coverage over the full width preventing any asphalt pick-up on plate bottom.
- Life lubricated vibration bearings.
- Block Paving Pad and Wheel Kit options also available.
- Customer colour options available.





**BATTERY POWER LEVEL INDICATOR ALWAYS VISIBLE FROM OPERATING POSITION**



**SIMPLE, SINGLE SWITCH OPERATION MAKES STARTING THE POWER UNIT EASY. 3-SPEED SELECTOR.**



**EMISSION FREE, LOW NOISE, BATTERY POWERED HONDA EGX MOTOR**



**OPTIONAL WHEEL KIT IS AVAILABLE**

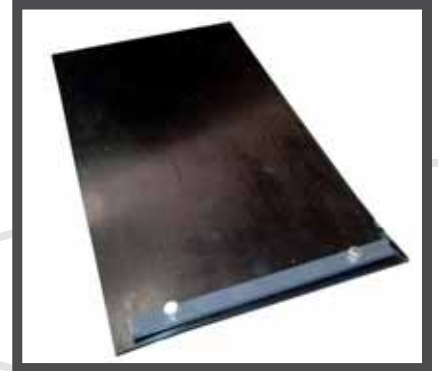

**OPTIONAL PAVING PAD IS AVAILABLE**



**LI-ION BATTERY, INTERCHANGEABLE WITH OTHER HONDA eGX POWERED ALTRAD BELLE PRODUCTS**



**ROBUST, PROTECTIVE BATTERY COVER, WITH STEEL SUB-FRAME**



# TECHNICAL SPECIFICATIONS

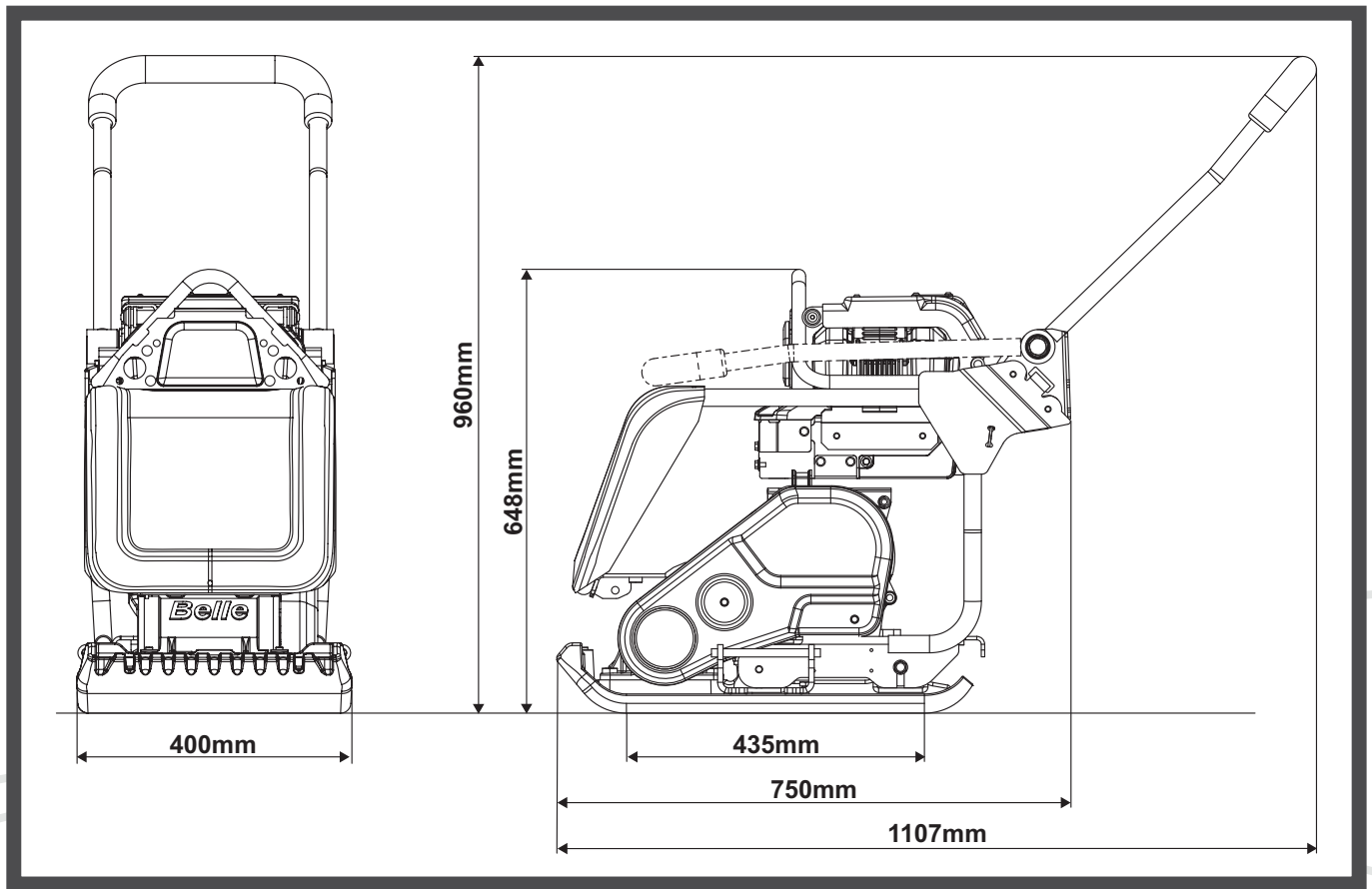

## Model

Part No.		FC4050E
Motor	(Hp / kW)	2.2 / 1.6
Vibrator Force	(KN)	13
Frequency	(Hz)	101
Static Pressure	(kg/m <sup>2</sup> )	560
Max Gradient	(°)	20
Travel Speed	(m/min)	20
HAV Level	(m/s <sup>2</sup> )	<2.5
Weight	(kg)	89
Motor RPM:		3600 / 3000 / 2800
Sound Power Level	(dB(A))	105

## PCX 13/40E+

## Options

OPP/108/DIO	eGX Battery
OPP/109/DIO	eGX Battery Storage Box <i>(Stores 1 x eGX Battery)</i>
OPP/110/DIO	eGX Battery Charger
OPP/111/DIO	Charger Storage Box
OPP/66/DIO	Block Paving Pad
OPP/71S/DIO	Water Spray Kit
OPP/112/DIO	Fixed Wheel Kit

## Battery

Battery Type		Li-Ion
Weight	(kg)	6.4
Dimensions LxWxH	(mm)	268 x 233 x 150
Voltage:	(V)	72
Energy Rating	(Wh)	720
Energy Capacity	(Ah)	10
Charge Time	(Hr)	1.25