

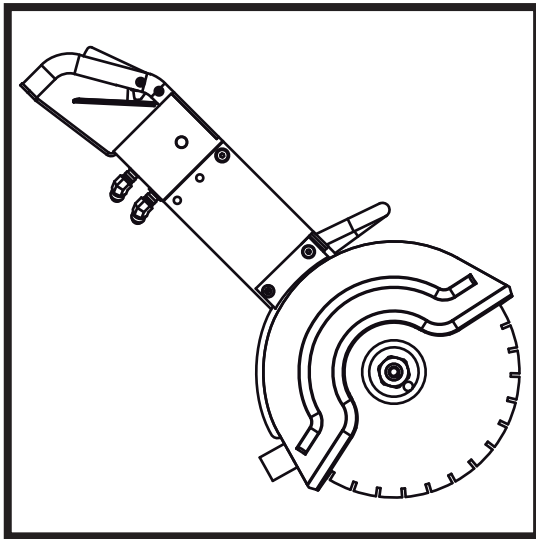

BELLE HDC 350

870/40003/2
03/22



Ⓒ Operators Manual

4

2

UKCA Declaration of Conformity

3

EC Declaration of Conformity

Declaration Of Conformity (DOC)

We, **Altrad Belle, Sheen, Nr. Buxton, Derbyshire, SK17 0EU, GB** declare that the DoC is issued under our sole responsibility and belongs to the followings product(s):



PRODUCT TYPE

MODEL.....

SERIAL No.....

DATE OF MANUFACTURE

SOUND POWER LEVEL
MEASURED /
.....(GUARANTEED)

WEIGHT.....



Object of the Declaration:

Hand-held hydraulic circular saw to be powered by an external hydraulic power source.

The object of the declaration described above is in conformity with the relevant **Statutory Requirements:**

- **2008 No. 1597** Supply of Machinery (Safety) Regulations 2008

The following designated standards and technical specifications have been applied:

- **EN ISO 12100:2010** Safety of machinery
- **BS EN ISO 11148-12:2012** Hand-held non-electric power tools. Safety requirements.
Circular, oscillating and reciprocating saws.

Technical Files are held by **Ray Neilson** at the Altrad Belle address stated above:-

Place of Declaration:-

Sheen,
Nr. Buxton,
Derbyshire,
SK17 0EU,
UK

Date of Declaration:-

February 2022

Signed by:

Ray Neilson

Managing Director
On behalf of Altrad Belle
Sheen, Derbyshire, UK

We, **Altrad Belle, Sheen, Nr. Buxton, Derbyshire, SK17 0EU, GB** declare that the DoC is issued under our sole responsibility and belongs to the followings product(s):



PRODUCT TYPE
MODEL.....
SERIAL No.....
DATE OF MANUFACTURE
SOUND POWER LEVEL
MEASURED /
.....(GUARANTEED)
WEIGHT.....



Object of the Declaration:

Hand-held hydraulic circular saw to be powered by an external hydraulic power source.

The object of the declaration described above is in conformity with the relevant **Union Harmonisation Legislation:**

- **2006/42/EC** New machinery directive

The following harmonised standards and technical specifications have been applied:

- **EN ISO 12100:2010** Safety of machinery
- **BS EN ISO 11148-12:2012** Hand-held non-electric power tools. Safety requirements. Circular, oscillating and reciprocating saws.

Technical Files are held by **Hugues Menager** at the following address:-
Altrad (Group Holding), 125 Rue du Mas Carbonnier, 34000, Montpellier, France.

Place of Declaration:-

Sheen,
Nr. Buxton,
Derbyshire,
SK17 0EU,
UK

Date of Declaration:-

March 2022

Signed by:

Ray Neilson

Managing Director
On behalf of Altrad Belle
Sheen, Derbyshire, UK



How To Use This Manual

This manual has been written to help you operate and service the HDC 350 safely.
This manual is intended for dealers and operators of the HDC 350.

Foreword

The '**Environment**' section gives instructions on how to handle the recycling of discarded apparatus in an environmentally friendly way.

The '**Machine Description**' section helps you to familiarize yourself with the machine's layout and controls.

The '**General Safety**' section explain how to use the machine to ensure your safety and the safety of the general public.

The '**Trouble Shooting Guide**' helps you if you have a problem with your machine.

The '**Maintenance**' section is to help you with the general maintenance and servicing of your machine.

The '**Warranty**' section details the nature of the warranty cover and the claims procedure.

Directives with regard to the notations.

Text in this manual to which special attention must be paid are shown in the following way:

 **CAUTION** *The product can be at risk. The machine or yourself can be damaged or injured if procedures are not carried out in the correct way.*

 **WARNING** *The life of the operator can be at risk.*

WARNING

 **WARNING** *Before you operate or carry out any maintenance on this machine **YOU MUST READ** and **STUDY** this manual.*

KNOW how to safely use the unit's controls and what you must do for safe maintenance. (NB Be sure that you know how to switch the machine off before you switch on, in case you get into difficulty.)

ALWAYS wear or use the proper safety items required for your personal protection. If you have **ANY QUESTIONS** about the safe use or maintenance of this unit, ASK YOUR SUPERVISOR OR CONTACT: **Altrad Belle: +44 (0) 1298 84606**

Contents

How to use this manual.....	4
Warning	4
Machine Description.....	5
Technical Data.....	5
Environment	5
Decals	6
General Safety	7 - 10
Installation	11
Pre-Start Checks.....	12
Start & Stop Procedure	12
Operating Instructions	12
Maintenance.....	13
Trouble Shooting Guide	13
Storage.....	13
Warranty	14
Replacement Parts.....	14
UKCA Declaration of Conformity.....	2
EC Declaration of Conformity.....	3

Altrad Belle reserves the right to change machine specification without prior notice or obligation.

Machine Description



The Altrad Belle HDC 350 is a powerful, light and compact machine designed for working together with Altrad Belle HPP range of Power Packs.

The Disc Cutter is designed for cutting through concrete, asphalt and steel with cutting blades for both dry and wet cutting. They can be used with both diamond blades and with abrasive discs. A dust collector can be connected to the blade guard for operation in areas where the use of water is not possible. No other use is permitted.

The simple hydraulic design with direct drive, reduces maintenance and provides consistent speed and torque.

The Altrad Belle HDC 350 is delivered with 2 m $\frac{3}{8}$ " tail-hoses with $\frac{1}{2}$ " 'Flat-Face' quick-release couplings.



- A. Trigger
- B. Valve Block
- C. Frame
- D. Front Handle
- E. Guard
- F. Hydraulic Motor
- G. Hydraulic Hose
- H. Water Valve
- I. Cutting Blade
- J. Quick Release Couplings

Technical Data



Model	HDC 350
Weight Without Hoses And Blade (kg)	9.8
Oil Flow Range (lpm)	20 - 30
Max Pressure Relief Valve Setting On Power Source (Bar)	170
EHTMA Category	C & D
Max Back Pressure In Return Line (Measured At Saw) (Bar)	30
Oil Working Temperature (°C)	30 - 70
Motor Performance (Max) (kw)	6.7
Motor Torque (Max) (Nm)	16
Circumferential Speed (m/sec)	46 - 75
Number Of Revolutions (rpm)	2500 - 4000
Blade Size (mm)	350
Arbor Hole Diameter (mm)	25.4
Cutting Depth (mm)	133
Required Cooling Capacity (kw)	Approx. 1.5
Sound Power Level (dB(A))	99
3 Axis Vibration	5.00

Environment



A used machine must be treated and scrapped in such a way that the greatest possible portion of the material can be recycled and any negative influence on the environment is kept as low as possible.

Before a used machine is scrapped it must be emptied and cleaned from all hydraulic oil. The remaining hydraulic oil must be deposited and any negative influence on the environment is to be kept as low as possible.

The machine is fitted with labels containing important information about personal safety and machine maintenance. The labels must be in such condition that they are easy to read. New labels can be ordered from the spare parts list.

Data Plate

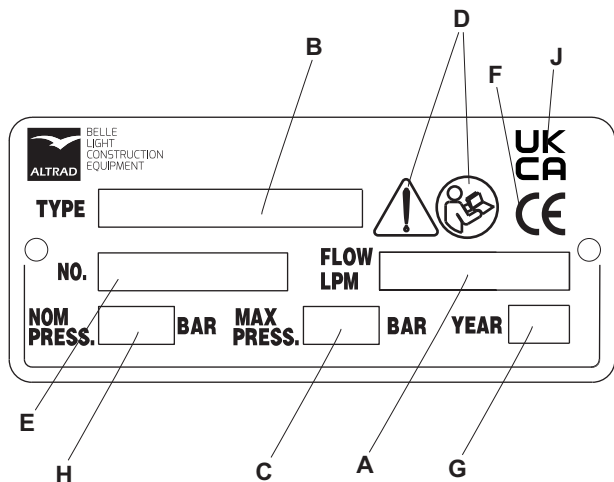

- A. Maximum permitted Hydraulic Oil flow
- B. Machine Type
- C. Maximum Relief Valve Setting
- D. The warning symbol together with the book symbol means that the user must read the safety and operating instructions before the machine is used for the first time.
- E. Serial Number (is also stamped in the valve housing).
- F. The CE symbol means that the machine is EC-approved. See the EC declaration which is at the front of the manual for more information.
- G. Year of Manufacture.
- H. Maximum Nominal Operating Pressure
- J. The UKCA symbol means that the machine is UKCA-approved. See the UKCA declaration which is at the front of the manual for more information.

Direction of Rotation

The red sticker on the blade guard shows the direction of rotation.

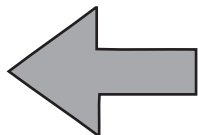

Cutting Blade Speed Rating

Never use a cutting blade with a lower speed rating than the machine's. A minimum cutting blade speed rating of 4400 rpm is recommended.

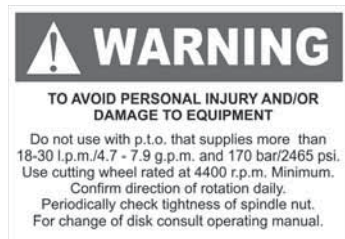

Noise Level Label

The label indicates the guaranteed noise level corresponding to EC-directive 2000/14/EC. See "Technical data" for accurate noise level.

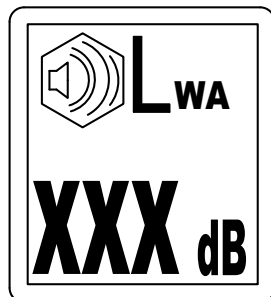

EHTMA Category

The machine is clearly marked with EHTMA categories. It is important that any power source used is in a compatible category. If any doubt, consult an authorised supervisor.



Only qualified and trained persons may operate or maintain the machine. They must be physically able to handle the bulk, weight, and power of the tool. Always use your common sense and good judgement.

Personal Protective Equipment (PPE)

Always use approved protective equipment. Operators and all other persons in the working area must wear protective equipment, including at a minimum:-

- Protective helmet
- Hearing protection
- Impact resistant eye protection with side protection
- Respiratory protection when appropriate
- Protective gloves
- Proper protective boots
- Appropriate work overall or similar clothing (not loose-fitting) that covers your arms and legs.

Drugs, Alcohol or Medication

Drugs, alcohol or medication may impair your judgment and powers of concentration. Poor reactions and incorrect assessments can lead to severe accidents or death.

- Never use the machine when you are tired or under the influence of drugs, alcohol or medication.
- No person who is under the influence of drugs, alcohol or medication may operate the machine.

Installation, Precautions

Whipping Hydraulic Hose

Hydraulic hoses under pressure can whip uncontrollably if screws loosen or are loosened. A whipping hydraulic hose can cause severe injuries.

- Depressurise the hydraulic system before loosening the connection of a hydraulic hose.
- Tighten the nuts on the connections of the hydraulic hoses to the required torque.
- Check that the hydraulic hose and the connections are not damaged.

Moving Parts

Risk for crushed hands and fingers.

- Never check bores or passages with hands or fingers.
- Never clean chips with fingers use brush instead.

Cutting Blade Hazard

A cutting blade may burst and cause personal injury or death.

- Check that no persons are within the safety distance, which is 15 m (49 ft). Never start cutting until the working zone is clear.
- Never use a cutting blade with a lower speed rating than the machine's.
- Inspect the disc before usage, check that it is not chipped, cracked or show signs of other defects.
- Check that the cutting blade is fitted correctly and does not show signs of damage.
- Always ensure that the guard is in place, is in good condition and correctly fitted before starting the machine.
- Ensure that the disc safety clamps are in place.
- Never use a cutting blade for any other purpose than it is intended for.

Hydraulic oil at high pressure

Thin jets of hydraulic oil under high pressure can penetrate the skin and cause permanent damage.

- Immediately consult a doctor if hydraulic oil has penetrated the skin.
- Never use your fingers to check for hydraulic fluid leaks.
- Keep your face away from any possible leaks.

Hydraulic Oil

Spilled hydraulic oil can cause burns, accidents due to slippery conditions and will also harm the environment.

- Take care of all spilled oil and handle it according to your safety and environmental regulations.
- Never dismount the hydraulic machine when the hydraulic oil is hot.
- Never run any hydraulic lines for attachment of the hydraulic machine through the drivers cab.

Skin Eczema

Hydraulic oil can cause eczema if it comes in contact with the skin.

- Avoid getting hydraulic oil on your hands.
- Always use protective gloves when working with hydraulic oil.
- Wash hands after contact with hydraulic oil.

Operation, Precautions

Operating Pressure

If the maximum operating pressure for the hydraulic machine is exceeded, it can result in material damage and personal injury.

- Always run the hydraulic machine with the correct operating pressure. See “Technical data”.

Explosion Hazard

If an insertion tool comes into contact with explosives or explosive gases, an explosion could occur. When working on certain materials and when using certain materials in machine parts, sparks and ignition can occur. Explosions will lead to severe injuries or death.

- Never operate the machine in any explosive environment.
- Never use the machine near flammable materials, fumes or dust.
- Make sure that there are no undetected sources of gas or explosives.

Unexpected Movements

The machine and the cutting blade might kick back towards the operator very suddenly and violently. If the upper quadrant of the blade touches an object, the cutting blade might move and may cause serious injury. To reduce risks:

- Never use the equipment if you suspect that it is damaged.
- Never start to cut with the upper quadrant of the Cutting blade.
- Always hold onto the machine with both hands and make sure the cutting blade is away from your body.
- Keep a good balance and a firm foothold.
- Always cut with the machine running at maximum speed.
- Make sure that the work piece is supported during cutting.
- Be careful when inserting the blade in the machine.
- Never cut above shoulder height.
- Never cut in wood.
- Never place the machine on the ground, before the blade has come to a complete stop.
- Never strike or abuse the equipment.

Dust and Fume Hazard

Dusts and/or fumes generated or dispersed when using the machine may cause serious and permanent respiratory disease, illness, or other bodily injury (for example, silicosis or other irreversible lung disease that can be fatal, cancer, birth defects, and/or skin inflammation).

Some dusts and fumes created by drilling, breaking, hammering, sawing, grinding and other construction activities contain substances known to the State of California and other authorities to cause respiratory disease, cancer, birth defects, or other reproductive harm.

Some examples of such substances are:

- Crystalline silica, cement, and other masonry products.
- Arsenic and chromium from chemically-treated rubber.
- Lead from lead-based paints. Dust and fumes in the air can be invisible to the naked eye, so do not rely on eye sight to determine if there is dust or fumes in the air.

To reduce the risk of exposure to dust and fumes, do all of the following:

- Perform site-specific risk assessment. The risk assessment should include dust and fumes created by the use of the machine and the potential for disturbing existing dust.
- Use proper engineering controls to minimize the amount of dust and fumes in the air and to minimize build-up on equipment, surfaces, clothing, and body parts. Examples of controls include: exhaust ventilation and dust collection systems, water sprays, and wet drilling. Control dusts and fumes at the source where possible. Make sure that controls are properly installed, maintained and correctly used.
- Wear, maintain and correctly use respiratory protection as instructed by your employer and as required by occupational health and safety regulations. The respiratory protection must be effective for the type of substance at issue (and if applicable, approved by relevant governmental authority).
- Work in a well ventilated area.
- If the machine has an exhaust, direct the exhaust so as to reduce disturbance of dust in a dust filled environment.
- Operate and maintain the machine as recommended in the operating and safety instructions
- Select, maintain and replace consumables/ inserted tools/ other accessory as recommended in the operating and safety instructions. Incorrect selection or lack of maintenance of consumables/ inserted tools/ other accessories may cause an unnecessary increase in dust or fumes.
- Wear washable or disposable protective clothes at the worksite, and shower and change into clean clothes before leaving the worksite to reduce exposure of dust and fumes to yourself, other persons, cars, homes, and other areas.
- Avoid eating, drinking, and using tobacco products in areas where there is dust or fumes.
- Wash your hands and face thoroughly as soon as possible upon leaving the exposure area, and always before eating, drinking, using tobacco products, or making contact with other persons.
- Comply with all applicable laws and regulations, including occupational health and safety regulations.
- Participate in air monitoring, medical examination programs, and health and safety training programs provided by your employer or trade organizations and in accordance with occupational health and safety regulations and recommendations. Consult with physicians experienced with relevant occupational medicine.
- Work with your employer and trade organization to reduce dust and fume exposure at the worksite and to reduce the risks. Effective health and safety programs, policies and procedures for protecting workers and others against harmful exposure to dust and fumes should be established and implemented based on advice from health and safety experts. Consult with experts.

Projectiles

Failure of the work piece, of accessories, or even of the machine itself may generate high velocity projectiles. During operating, splinters or other particles from the working material may become projectiles and cause personal injury by striking the operator or other persons. To reduce these risk:

- Use approved personal protective equipment and safety helmet, including impact resistant eye protection with side protection
- Make sure that no unauthorised persons trespass into the working zone.
- Keep the workplace free from foreign objects.
- Ensure that the work piece is securely fixed.

Slipping, Tripping and Falling Hazards

There is a risk of slipping or tripping or falling, for example tripping on the hoses or on other objects.

Slipping or tripping or falling can cause injury. To reduce this risk:

- Always make sure that no hose or other object is in your way or in any other person's way.
- Always make sure you are in a stable position with your feet as far apart as your shoulders width and keeping a balanced body weight.

Motion Hazards

When using the machine to perform work-related activities, you may experience discomfort in the hands, arms, shoulders, neck, or other parts of the body.

- Adopt a comfortable posture whilst maintaining secure footing and avoiding awkward off-balanced postures.
- Changing posture during extended tasks may help avoid discomfort and fatigue.
- In case of persistent or recurring symptoms, consult a qualified health professional.

Material Hazard

During operating, the material that you operate in can become hot and fall down, which can cause a fire or even an explosion. This can lead to personal injury or death.

- Always consider the direction of the falling object.
- Wear fire resistant clothing and have a bucket of water nearby.

Trapping Hazard

There is risk of neck ware, hair, gloves and clothes getting dragged into or caught by a rotating insertion tool or accessories. This may cause choking, scalping, lacerations or death. To reduce the risk:

- Never grab or touch a rotating blade.
- Avoid wearing clothing, neck ware or gloves that may get caught.
- Cover long hair with a hair net.

Grinding Hazard

Using the side of the cutting blade can cause that the blade jam or break. Pressure from the side can damage the cutting blade. This can result in personal injury. To reduce risk:

- Never grind by using the side of the cutting blade.
- Never use the cutting blade if it has been damaged.
- Never grind over the maximum peripheral speed.
- Always feed the machine down in line with the cutting blade.
- Only use the cutting section.
- Never pull the machine to one side.

Vibration Hazards

Normal and proper use of the machine exposes the operator to vibration. Regular and frequent exposure to vibration may cause, contribute to, or aggravate injury or disorders to the operator's fingers, hands, wrists, arms, shoulders and/or nerves and blood supply or other body parts, including debilitating and/or permanent injuries or disorders that may develop gradually over periods of weeks, months, or years. Such injuries or disorders may include damage to the blood circulatory system, damage to the nervous system, damage to joints, and possibly damage to other body structures.

If numbness, persistent recurring discomfort, burning sensation, stiffness, throbbing, tingling, pain, clumsiness, weakened grip, whitening of the skin, or other symptoms occur at any time, when operating the machine or when not operating the machine, stop operating the machine, tell your employer and seek medical attention. Continued use of the machine after the occurrence of any such symptom may increase the risk of symptoms becoming more severe and/or permanent.

Operate and maintain the machine as recommended in these instructions, to prevent an unnecessary increase in vibration.

The following may help to reduce exposure to vibration for the operator:

- Let the tool do the job. Use a minimum hand grip consistent with proper control and safe operation.
- If the machine has vibration absorbing handles, keep them in a central position, avoid pressing the handles into the end stops.
- When the percussion mechanism is activated, the only body contact with the machine you should have are your hands on the handle or handles. Avoid any other contact, for example supporting any part of the body against the machine or leaning onto the machine trying to increase the feed force. It is also important not to keep the start and stop device engaged while extracting the tool from the broken work surface.
- Make sure that the inserted tool is well-maintained (including sharpness, if a cutting tool), not worn out, and of the proper size. Insertion tools that are not well-maintained, or that are worn out, or that are not of the proper size result in longer time to complete a task (and a longer period of exposure to vibration) and may result in or contribute to higher levels of vibration exposure.
- Immediately stop working if the machine suddenly starts to vibrate strongly. Before resuming the work, find and remove the cause of the increased vibrations.
- Never grab, hold or touch the inserted tool when using the machine.
- Participate in health surveillance or monitoring, medical exams and training programs offered by your employer and when required by law.
- When working in cold conditions wear warm clothing and keep hands warm and dry.



General Safety

Electrical Hazard

The machine is not electrically insulated. If the machine comes into contact with electricity, serious injuries or death may result.

- Never operate the machine near any electric wire or other source of electricity.
- Make sure that there are no concealed wires or other sources of electricity in the working area.

Concealed Object Hazard

During operating, concealed wires and pipes constitute a danger that can result in serious injury.

- Check the composition of the material before operating.
- Watch out for concealed cables and pipes for example electricity, telephone, water, gas and sewage lines etc.
- If the inserted tool seems to have hit a concealed object, switch off the machine immediately.
- Make sure that there is no danger before continuing.

Involuntary Start

Involuntary start of the machine may cause injury.

- Keep your hands away from the start and stop device until you are ready to start the machine.
- Learn how the machine is switched off in the event of an emergency.
- Stop the machine immediately in all cases of power supply interruption.

Noise Hazard

High noise levels can cause permanent and disabling hearing loss and other problems such as tinnitus (ringing, buzzing, whistling, or humming in the ears). To reduce risks and prevent an unnecessary increase in noise levels:

- Risk assessment of these hazards and implementation of appropriate controls is essential.
- Operate and maintain the machine as recommended in these instructions.
- Select, maintain and replace the insertion tool as recommended in these instructions.
- If the machine has a silencer, check that it is in place and in good working condition.
- Always use hearing protection.
- Use damping material to prevent work pieces from 'ringing'.

Involuntary Start

Involuntary start of the machine may cause injury.

- Keep your hands away from the start and stop device until you are ready to start the machine.
- Learn how the machine is switched off in the event of an emergency.
- Stop the machine immediately in all cases of power supply interruption.

NEVER exceed the maximum flow stated on the machine, as this might lead to failure of the cutting blade and damage to the machine.

Maintenance, Precautions

Machine Modification

Any machine modification may result in bodily injuries to yourself or others.

- Never modify the machine. Modified machines are not covered by warranty or product liability.
- Always use original parts, insertion tools and accessories approved by Altrad Belle.
- Change damaged parts immediately.
- Replace worn components in good time.

Insertion Tool Hazards

Accidental engagement of the start and stop device during maintenance or installation can cause serious injuries, when the power source is connected.

- Never inspect, clean, install, or remove the insertion tool while the power source is connected.

Hot Insertion Tool

The tip of the insertion tool can become hot and sharp when used. Touching it can lead to burns and cuts.

- Never touch a hot or sharp insertion tool.
- Wait until the insertion tool has cooled down before carrying out maintenance work.

Storage, Precautions

- Keep the machine and tools in a safe place, out of the reach of children and locked up.

Hoses

For connection on the machine, the hydraulic hose must be approved for a working pressure of at least 160 bar (2300 psi) and have a 12.7 mm (½ in.) inner diameter. To resist exterior wear and tear, we recommend using a 2-layer hydraulic hose. The machine connection marked P (pump) is the oil inlet, and the connection marked T (tank) is the oil outlet.

Always connect both hoses and make sure that all hose connections are tight. Never carry the machine by the hose.

Quick-Release Couplings

The original hydraulic hoses are fitted with Flat-Face quick-release couplings that are strong and easy to clean. The quick-release couplings are fitted so that the male connection supplies oil and the female connection receives oil.

Wipe all couplings clean before connecting. Ensure that couplings are clean and correctly engaged before operation. Failure to do so may result in damage to the quick couplings and cause overheating and cause foreign matter to enter the hydraulic system.

Hydraulic Oil

In order to protect the environment, Altrad Belle recommends the use of biologically degradable hydraulic oil. No other fluids must be used.

- ◆ Viscosity (preferred) 20-40 cSt.
- ◆ Viscosity (permitted) 15-100 cSt.
- ◆ Viscosity index Min. 100.

Standard mineral or synthetic oil can be used. Make sure to only use clean oil and filling equipment.

When the machine is used continuously, the oil temperature will stabilise at a level which is called the working temperature. This will, depending on the type of work and the cooling capacity of the hydraulic system, be between 20-40°C (68-104°F) above the ambient temperature. At working temperature, the oil viscosity must lie within the preferred limits. The viscosity index indicates the connection between viscosity and temperature. A high viscosity is therefore preferred, because the oil can then be used within a wider temperature range. The machine must not be used, if oil viscosity fails to remain within the permitted area, or if the working temperature of the oil does not fall between 20°C (68°F) and 70°C (158°F).

Cutting Blades

High-quality cutting blades are often most economical. Lower quality blades often have inferior cutting capacity and a shorter service life, which results in a higher cost in relation to the quantity of material that is cut. The cutting blades must be approved for free hand cutting machines and rated for minimum 4400 rpm.

Selecting the right Cutting Blade

The Disc Cutter can be used with both diamond blades and with the more traditional abrasive discs. Store and handle the abrasive product with care in accordance with manufacturer's instructions.

Abrasive Discs

Using abrasive discs, the Disc Cutter can be used for cutting steel, concrete, asphalt or other material depending on the blade type.

Diamond Blades

Diamond blades are ideal for masonry, reinforced concrete and other composite materials. They are not, however, recommended for cutting steel.

There is a wide selection of blades with diamond segments for various kinds of material. The local environment (type of stone in the concrete or asphalt) will often determine which type of diamond blade is the ideal and most economic solution. Diamond Blades are generally available as dry cutting or wet cutting blades. If dry cutting blades are used, a dust collector can be connected to the blade guard for operation in areas where no water can be accepted.

It is, however, most common to use a wet cutting diamond blade and a small amount of water to remove the dust and cool the diamond segments. With a diamond cutting blade, the Disc Cutter can be used underwater without any modification.



CAUTION

Never cool a hot insertion tool in water, it can result in brittleness and early failure.

Fitting and Removing the Cutting Blade

1. Untighten and remove the nut.
2. Remove the washer.
3. Remove and change the cutting blade.
4. Attach the new cutting blade. Be aware of the direction of rotation. If there is an arrow on the blade, this must point in the same direction as the red arrow on the blade guard.
5. Attach the washer above the cutting blade and tighten the nut.
6. Make sure that the blades/discs are mounted correctly and tightened before use.
7. Start the machine at low speed for one minute in a safe position and check the direction of rotation of the cutting blade. Stop the machine immediately if it starts to vibrate strongly or if you see other defects.



Pre-start Checks

The following checks should be made each time you start to use the Disc Cutter. All these checks concern the serviceability of the Disc Cutter. Some concern your safety:

- Clean all safety stickers. Replace any that are missing or cannot be read.
- Inspect the hoses generally for signs of damage.
- Inspect the blade for wear and damage. Do not use an excessively worn or damaged blade.
- Connect the machine.
- Ensure that the hydraulic couplings are clean and fully serviceable.
- Never invert the Disc Cutter without first isolating it from the power source. The blade might be ejected forcefully while connecting it, if the Disc Cutter is connected to the power source.
- Ensure that any power source you plan to use is compatible with the Disc Cutter that is used, see "Technical data". Use recommended LFD oil flow divider, if the flow from the power source can exceed the maximum allowed oil flow.
- Never exceed the maximum relief valve setting stated on the machine.
- Always connect P and T hoses before starting.



Start and Stop Procedure



WARNING

*Before you operate or carry out any maintenance on this machine **YOU MUST READ** and **STUDY** this manual.*

Start

- Connect the hoses and couplings.
- Mount the Disc Cutter in the cart (if a cart is to be used).
- Start the power source.
- Activate the water supply or the dust collector, if they are being used.
- Place the Disc Cutter at a right angle to the surface to be cut and activate the trigger.

Stop

- Release the trigger. Keep a firm grip on the Disc Cutter, until the cutting blade has come to a complete stop.
- It can take up to ten seconds for the cutting blade to stop completely.
- Stop the power source.
- Disconnect the hoses and fit the protective caps to the quick-release couplings.



Operating Instructions



CAUTION

Diamond blades can become dull when the wrong feeding pressure is used or when cutting in certain materials, such as heavily reinforced concrete. Working with a blunt diamond blade causes overheating, which can result in diamond segments coming loose. Sharpen the blade by cutting in a soft material such as sandstone or brick.



CAUTION

The blade can become out-of-round and vibrate if an excessive feeding pressure is used. A lower feeding pressure can stop the vibration. Otherwise replace the blade. The blade must be of the recommended type for the material to be cut.

Cutting

The technique described below is of a general character. Check information for each cutting blade regarding individual cutting characteristics (for example, diamond blades require less feeding pressure than abrasive discs).

1. During operation the working zone must be cleared.
2. Always hold the machine in a firm grip with both hands. Hold it so that the thumbs and fingers grip round the handles.
3. Stand in a stable position with your feet well away from the cutting blade.
4. Check that the cutting blade is not in contact with anything when the machine is started.
5. Always cut at maximum speed. Check regularly that the speed of the cutting blade is not higher than what is marked on it.
6. Support the workpiece in such a way, that the cut slot would open up during the cutting process.
7. Never grind with a cutting disc.
8. Start cutting smoothly, allowing the machine to work without forcing or pressing in the blade.
9. Move the blade slowly forwards and backwards to achieve a small contact area between the blade and the material to be cut. This reduces the temperature of the blade and ensures effective cutting.
10. Feed the machine down in line with the blade.
11. The cutting blade guard should be adjusted so that the rear section is in line with the work piece. Splinters and sparks from the material being cut are then collected by the guard and led away from the operator. Make sure that sparks do not land on clothing.
12. If the cutting blade gets jammed in a cut, shut off the grinder and ease the wheel free. Before continue make sure it is not damaged.

When Taking a Break

- During all breaks you must place the machine in such a way that there is no risk for it to be unintentionally started. Make sure to place the machine on the ground, so that it can not fall.
- In the event of a longer break or when leaving the workplace: Switch off the power supply and then bleed the machine by activating the start and stop device.

Maintenance



Regular maintenance is a basic requirement for the continued safe and efficient use of the machine. Follow the maintenance instructions carefully.

- Before starting maintenance on the machine, clean it in order to avoid exposure to hazardous substances. See “Dust and fume hazards”
- Use only authorised parts. Any damage or malfunction caused by the use of unauthorised parts is not covered by warranty or product liability.
- When cleaning mechanical parts with solvent, comply with appropriate health and safety regulations and ensure there is satisfactory ventilation.
- For major service of the machine, contact your nearest authorised workshop.
- After each service, check that the machine’s vibration level is normal. If not, contact your nearest authorised workshop.

Every Day

Before undertaking any maintenance on hydraulic machines, always switch off the oil supply and bleed the machine by depressing the start and stop device Then disconnect the hydraulic hose from the machine.

- Clean and inspect the machine and its functions each day before the work commences.
- Check if the spindle thread, the guard (the disc may not touch the guard) and the flange are in good condition.
- Conduct a general inspection for leaks, damage, and wear.
- Change damaged parts immediately.
- Replace worn components in good time.
- Make sure that all the attached and related equipment, such as hoses and flow dividers are properly maintained.
- If the machine has been dropped, carefully examine the disc.
- Ensure that the disc dimensions are compatible and that it fits the spindle.
- Always plug hoses and nipples with clean and tight plugs when dismantling.
- Check tightness of nuts, bolts, screws and hose fittings after the first days of operation and thereafter in accordance with the maintenance schedule.

Every Three Months

- Check tightness of nuts, bolts, screws and hose fittings.

Every 300 Hours of Operation or Every Year

- Check moving parts, seals and bolts for wear and cracks. Replace if necessary.
- Check the function of the machine.

Troubleshooting Guide



Problem	Cause	Remedy
Saw turns too fast or develops too much torque.	Connected to improper power source.	Use proper power source.
	Power source not adjusted correctly.	Adjust power source flow and pressure settings as per the manufacturer’s instructions.
Saw will not turn at all or turns too slowly.	Power supply defect.	Disconnect saw and check power supply.
	Valve block defect.	Repair or replace.
	Motor defect.	Disconnect power source and try to turn the motor shaft by hand. Repair or replace.
Saw does not develop enough torque (insufficient power to cut material)	Power supply defect.	Repair or replace.
	Motor defect.	Repair or replace.

Storage



Check that the machine is properly cleaned before storage.

- Store the machine in a dry place.
- Keep the machine and tools in a safe place, out of the reach of children and locked up.



Warranty

Your new Altrad Belle HDC 350 is warranted to the original purchaser for a period of one-year (12 months) from the original date of purchase. The Altrad Belle warranty is against defects in design, materials and workmanship.

The following are not covered under the Altrad Belle warranty:

1. Damage caused by abuse, misuse, dropping or other similar damage caused by or as a result of failure to follow assembly, operation or user maintenance instructions.
2. Alterations, additions or repairs carried out by persons other than Altrad Belle or their recognised agents.
3. Transportation or shipment costs to and from Altrad Belle or their recognised agents, for repair or assessment against a warranty claim, on any machine.
4. Materials and/or labour costs to renew, repair or replace components due to fair wear and tear.

The following components are not covered by warranty.

- Drivebelt/s
- Engine air filter
- Engine spark plug

Altrad Belle and/or their recognised agents, directors, employees or insurers will not be held liable for consequential or other damages, losses or expenses in connection with or by reason of or the inability to use the machine for any purpose.

Warranty Claims

All warranty claims should firstly be directed to Altrad Belle, either by telephone, by Fax, by Email, or in writing.

For warranty claims:

Tel : +44 (0)1298 84606,

Fax : +44 (0)1298 84073,

Email : warranty.dept@altrad-belle.com

or Write to:

Altrad Belle Warranty Department,
Sheen, Nr. Buxton
Derbyshire
SK17 0EU
England

Warranty Registration:

In the bid for ALTRAD Belle to become greener and more eco friendly, we have now introduced online Warranty registration. To access the registration page of our website, please use the following address:-

http://www.bellegroup.com/index.php?p=warranty_registration

Alternatively, please scan the adjacent QR Code (Quick Response Code) using your smartphone to access the registration page.



Replacement Parts

When maintaining this product only the manufacturers original, genuine replacement parts may be used.

The user will lose any possible claims if replacement parts used are other than the makers original replacement parts.

Replacement parts for this product can be ordered online 24 hours a day, 7 days a week at www.Altrad-Belle247.com

For more information regarding the availability of replacement parts for this product, please contact Altrad Belle using the following contact details:-

Tel:- +44 (0)1298 84606

Fax:- +44 (0)1298 84073

Email:- sales@altrad-belle.com

Alternatively, please scan the adjacent QR Code (Quick Response Code) using your smartphone to access the Altrad Belle online parts portal.





BELLE
LIGHT
CONSTRUCTION
EQUIPMENT

ALTRAD BELLE

Sheen, Nr. Buxton, Derbyshire, SK17 0EU, GB

Tel. +44 (0)1298 84606 - Fax +44 (0)1298 84722 - Email: sales@altrad-belle.com

www.Altrad-Belle.com

EU IMPORTER ADDRESS

ADRESSE DE L'IMPORTATEUR - DIRECCIÓN DEL IMPORTADOR - ENDEREÇO DO IMPORTADOR - ADRES IMPORTEUR

IMPORTØRENS ADRESSE - IMPORTEUR ADRESSE - INDIRIZZO DELL'IMPORTATORE - IMPORTÖRENS ADRESS - IMPORTØRADRESSE

MAAHANTUOJAN OSOITE - ADRES IMPORTERA - IMPORTIJA AADRESS - IMPORTĚTĀJA ADRESE - IMPORTUOTOJO ADRESAS

ADRESA DOVOZCE - ADRESA IMPORTATORULUI - IMPORTÓR CÍME - ADRESA UVOZNIKA - ÍTHALATÇI ADRESI - ADRESA DOVOZCU

ALTRAD (Group Holding)

125, Rue du Mas Carbonnier, 34000, Montpellier, France

Tel. +33 (0) 4 67 50 53 66 - Email: admin@altrad.com

www.altrad.com